



FUJI ELECTRIC

**SPLIT TYPE ROOM AIR
CONDITIONER
FLOOR CONSOLE /
UNDER CEILING
DUAL type (50Hz)**

SERVICE MANUAL

Models	Indoor unit	Outdoor unit
	RYT-14	ROY-14AA
	RYT-14R	ROY-14RA
	RYT-18AC	RO-18AC
	RYT-18RB	ROW-18RB
	RYT-24CA	ROW-24CA
	RYT-24RE	ROW-24RE

C O N T E N T S

SPECIFICATIONS	1
OUTLINE AND DIMENSIONS	3
CIRCUIT DIAGRAM	5
REFRIGERANT SYSTEM DIAGRAM	9
P.C. BOARD LAYOUTS	12
INDOOR PRINTED CIRCUIT BOARD CIRCUIT DIAGRAM	14
DISASSEMBLY ILLUSTRATION	17
PARTS LIST	32



Большая библиотека технической документации

<https://splitsystema48.ru/instrukcii-po-ekspluatatsii-kondicionerov.html>

каталоги, инструкции, сервисные мануалы, схемы.

S P E C I F I C A T I O N S

TYPE		COOLING	COOL & HEAT	COOLING	COOL & HEAT	COOLING	COOL & HEAT
INDOOR UNIT		RYT-14	RYT-14R	RYT-18AC	RYT-18RB	RYT-24CA	RYT-24RE
OUTDOOR UNIT		ROY-14AA	ROY-14RA	RO-18AC	ROW-18RB	ROW-24CA	ROW-24RE
COOLING CAPACITY	(W)	4,000 – 4,100	3,950 – 4,050	5,300 – 5,400	5,200 – 5,300	6,550 – 6,650	6,500 – 6,600
HEATING CAPACITY	(W)	—	4,900 – 5,000	—	5,700 – 5,800	—	7,600 – 7,700

ELECTRICAL DATA

POWER SOURCE	(V)	220 – 240						
FREQUENCY	(Hz)	50						
RUNNING CURRENT	(A)	COOLING	7.9 – 8.3	7.6 – 8.0	10.2 – 10.4	9.5 – 9.5	11.7 – 11.0	11.6 – 11.1
		HEATING	—	7.6 – 8.0	—	9.0 – 9.1	—	11.2 – 10.6
INPUT WATTS	(W)	COOLING	1,670 – 1,800	1,620 – 1,760	2,050 – 2,150	2,050 – 2,150	2,560 – 2,590	2,550 – 2,650
		HEATING	—	1,610 – 1,730	—	1,900 – 2,000	—	2,440 – 2,540
E.E.R	(W/W)	COOLING	2.39 – 2.28	2.44 – 2.30	2.59 – 2.51	2.54 – 2.47	2.56 – 2.61	2.63 – 2.57
		HEATING	—	3.04 – 2.89	—	3.00 – 2.97	—	3.11 – 3.30
MOISTURE REMOVAL	(ℓ/h)	1.6		2.0		3.4		
AIR CIRCULATION-Hi	(m³/hr)	640		800		900		

COMPRESSOR

TYPE	Hermetic type, Permanent split condenser, 2 pole, Single phase, Induction motor							
CODE	QJ282PC24A		PSF250D62		PH36VTTT		NH44VNBT	
REFRIGERANT	R-22	(g)	1,090	1,050	1,500	1,950	1,900	2,320

FAN MOTOR

POWER SOURCE	(V)	240					
INDOOR UNIT	TYPE	MFA-14CTT		MFA-18CTT		MFA-24CTAT	
	HI-SPEED	(r.p.m.)	850	1,030		1,180	
	MED-SPEED	(r.p.m.)	760	890		1,040	
	LO-SPEED	(r.p.m.)	670	770		900	
OUTDOOR UNIT	TYPE	MFB-14VTT		MFB-247FBT	MFB-252TAT	MFB-247FB	MFB-252TA
	FAN SPEED	(r.p.m.)	750	790	Hi : 735 Lo : 280	735	Hi : 735 Lo : 280

DIMENSIONS

INDOOR UNIT	H x W x D (mm)	199 x 990 x 655					
OUTDOOR UNIT		530 x 750 x 250			643 x 840 x 336		

WEIGHT

INDOOR UNIT	GROSS / NET (kg)	39 / 30					
OUTDOOR UNIT		39 / 37	40 / 38	67 / 59	68 / 76	65 / 73	77 / 69

ADDITIONAL REFRIGERANT CHARGE

PIPE LENGTH		5 m (16 ft)	7.5 m (25 ft)	10 m (33 ft)	15 m (49 ft)	20 m (66 ft)
FULL CHARGE AMOUNT	RYT-14	1,090 g (38.4 oz)	1,165 g (41.1 oz)	1,240 g (43.7 oz)	—	—
	RYT-14R	1,100 g (38.8 oz)	1,175 g (41.4 oz)	1,250 g (44.1 oz)	—	—
	RYT-18AC	1,500 g (52.9 oz)	1,540 g (54.3 oz)	1,580 g (55.7 oz)	1,660 g (58.6 oz)	1,740 g (61.4 oz)
	RYT-18RB	1,950 g (68.8 oz)		2,075 g (73.2 oz)	2,325 g (82.0 oz)	2,575 g (90.8 oz)
	RYT-24CA	1,900 g (67.0 oz)		1,950 g (68.8 oz)	2,050 g (72.3 oz)	2,150 g (75.8 oz)
	RYT-24RE	2,320 g (81.8 oz)		2,400 g (84.7 oz)	2,480 g (87.5 oz)	2,560 g (90.3 oz)

Note : In the case that 5 m for RYT-14, RYT-14R, RYT-18AC, 7.5 m for RYT-18RB, RYT-24CA, RYT-24RE are exceeded, when using a connection pipe other than that in the table, charge additional refrigerant with 30 g (1.1 oz) / 1 m (3.3 ft) for RYT-14 and RYT-14R, 50 g (1.76 oz) / 1 m (3.3 ft) for RYT-18RB, 20 g (0.71 oz) / 1 m (3.3 ft) for RYT-24CA, 16 g (0.56 oz) / 1 m (3.3 ft) for RYT-18AC and RYT-24RE as the criteria.

OUTLINE AND DIMENSIONS

INDOOR UNIT

Unit : mm

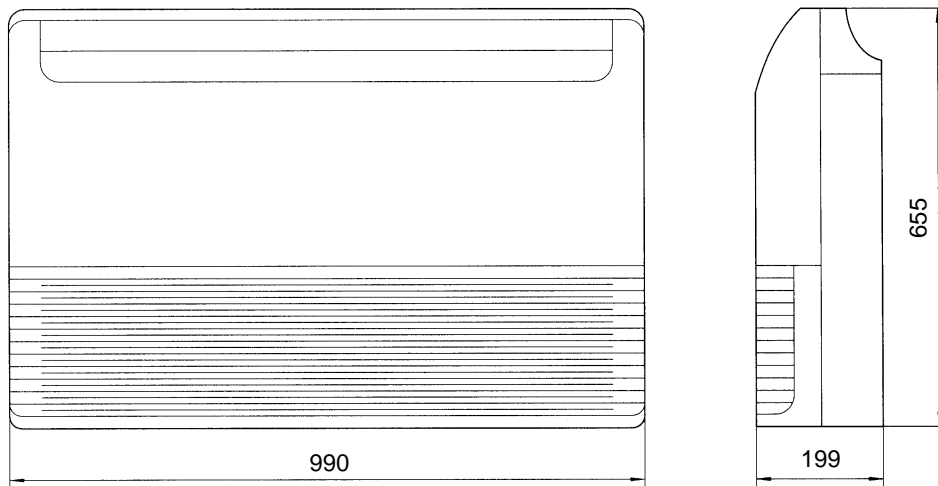

[Rear View]

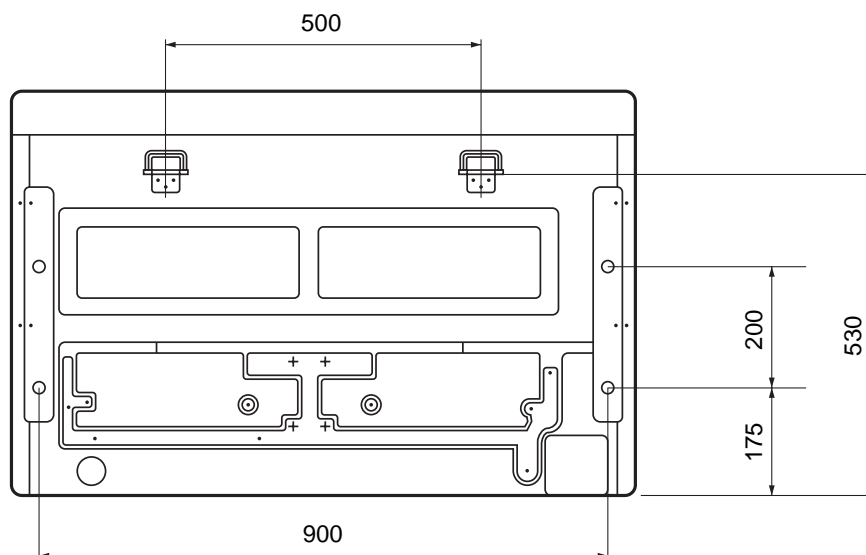

OUTDOOR UNIT

Models : ROY-14AA
ROY-14RA

Unit : mm

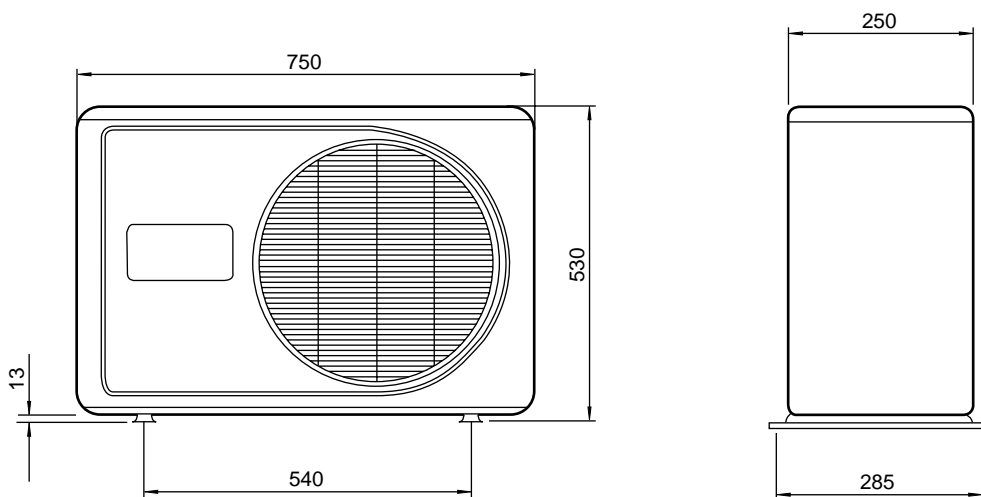

Models : RO-18AC
ROW-18RB
ROW-24CA
ROW-24RE

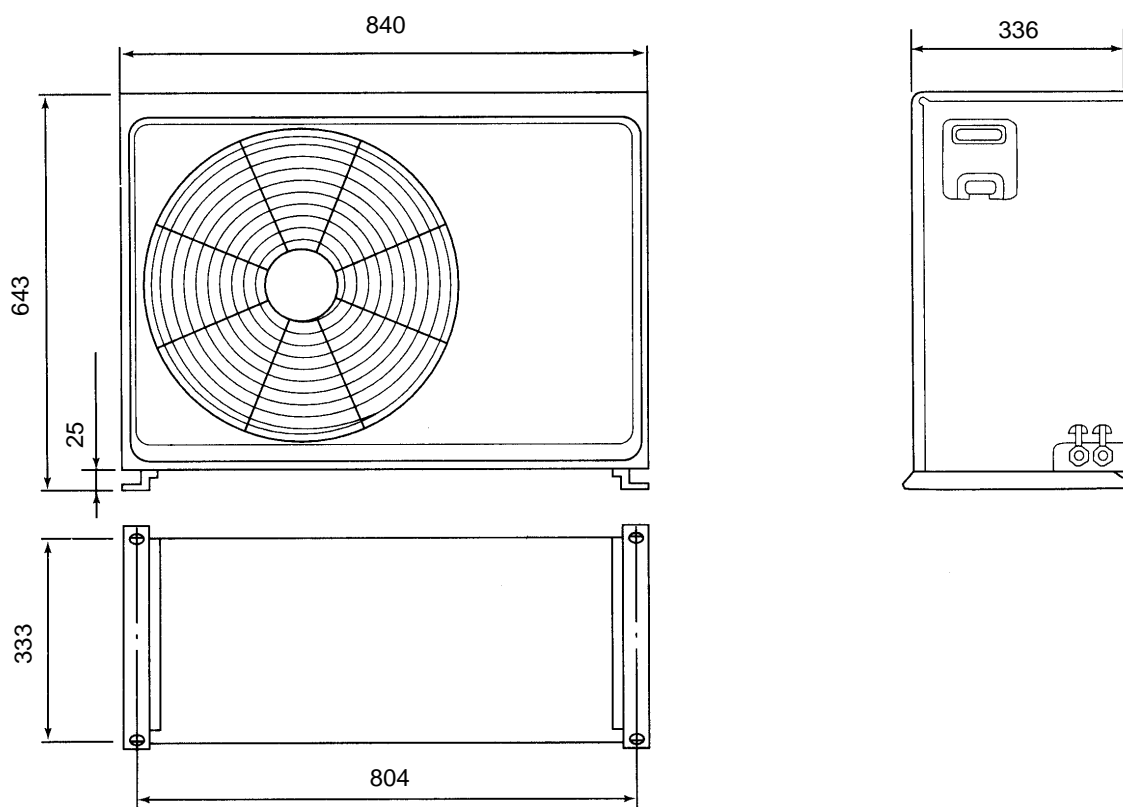

CIRCUIT DIAGRAM

Models : RYT-14 / ROY-14AA

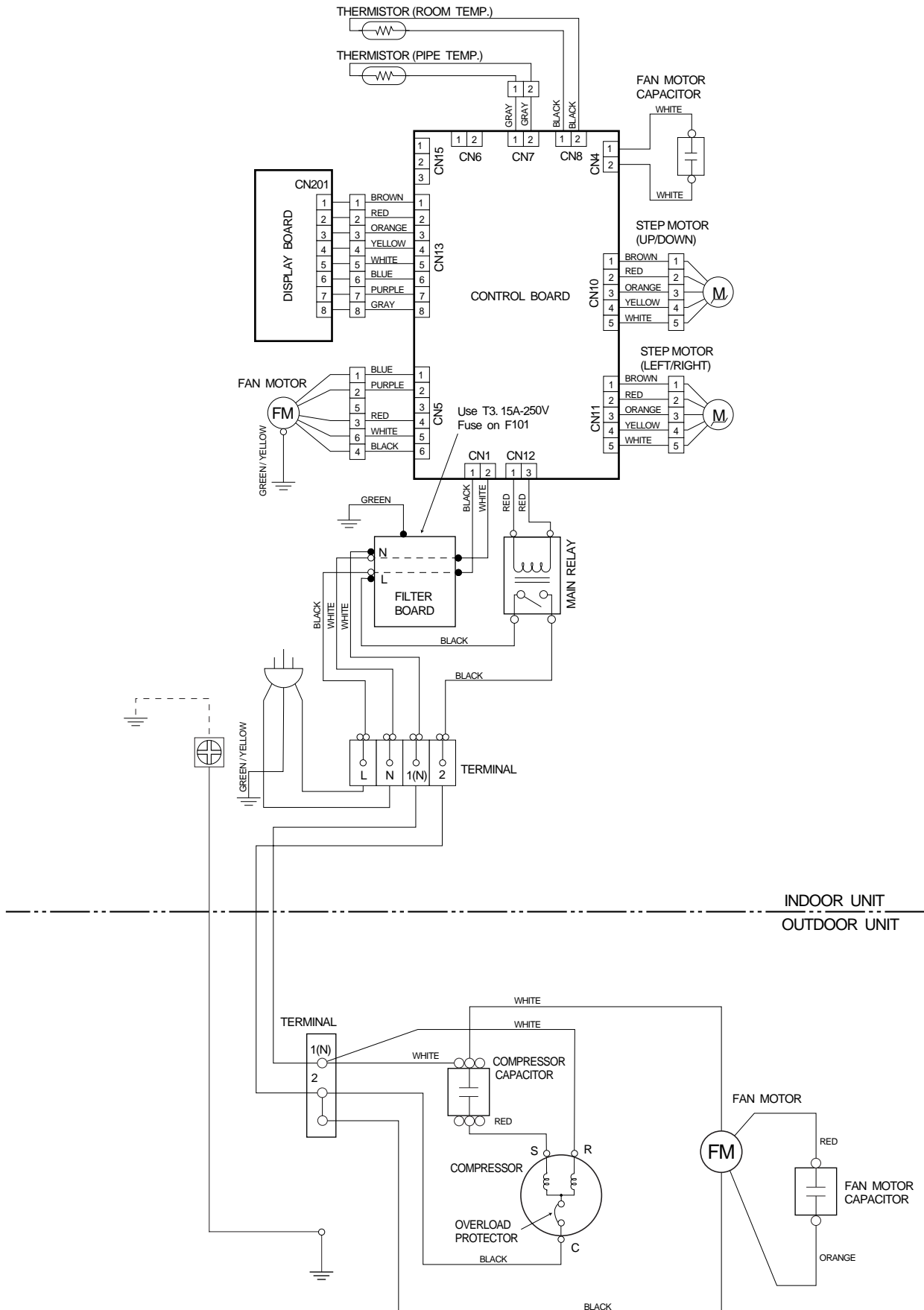

Models : RYT-14R / ROY-14RA

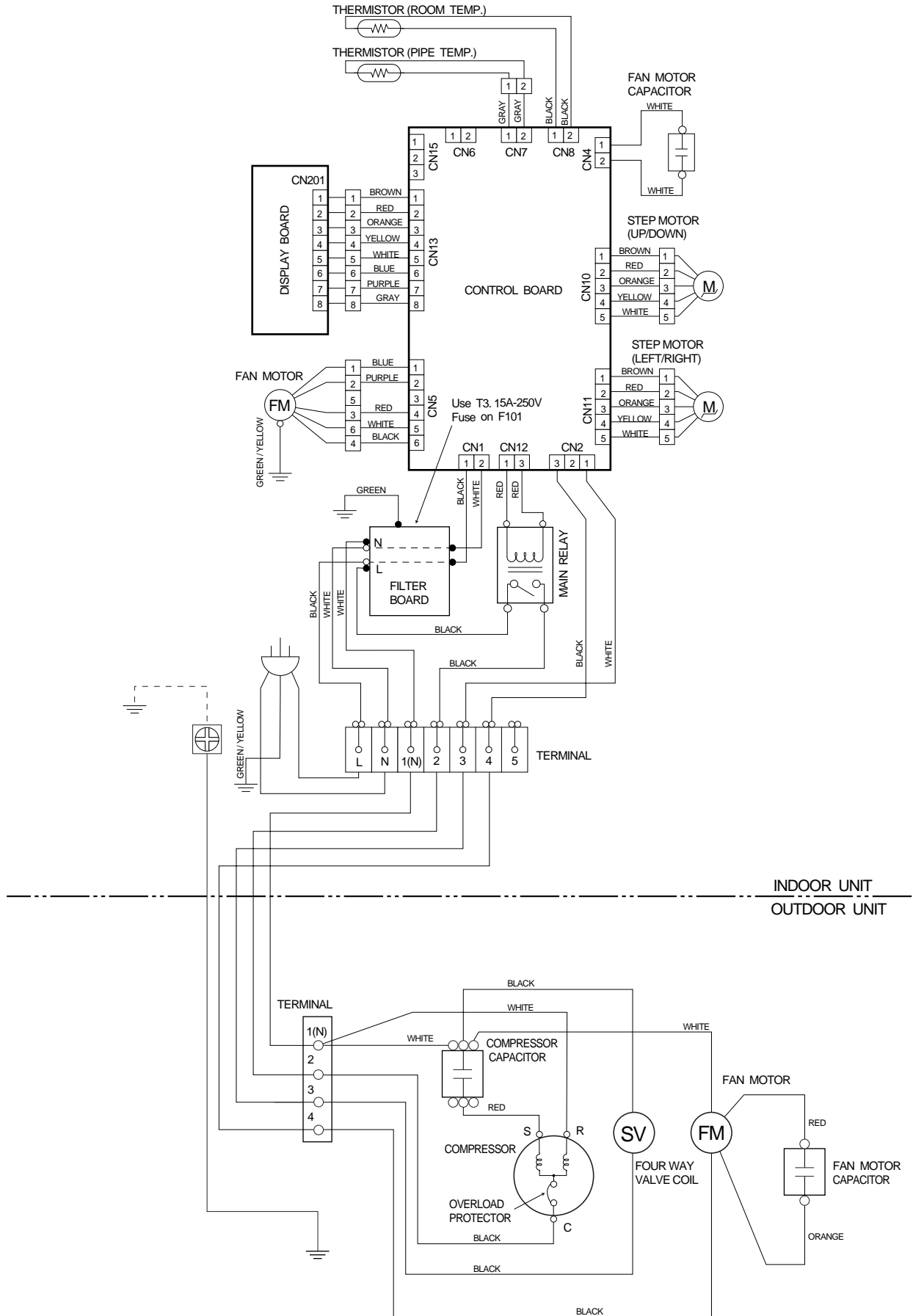

**Models : RYT-18AC / RO-18AC
RYT-24CA / ROW-24CA**

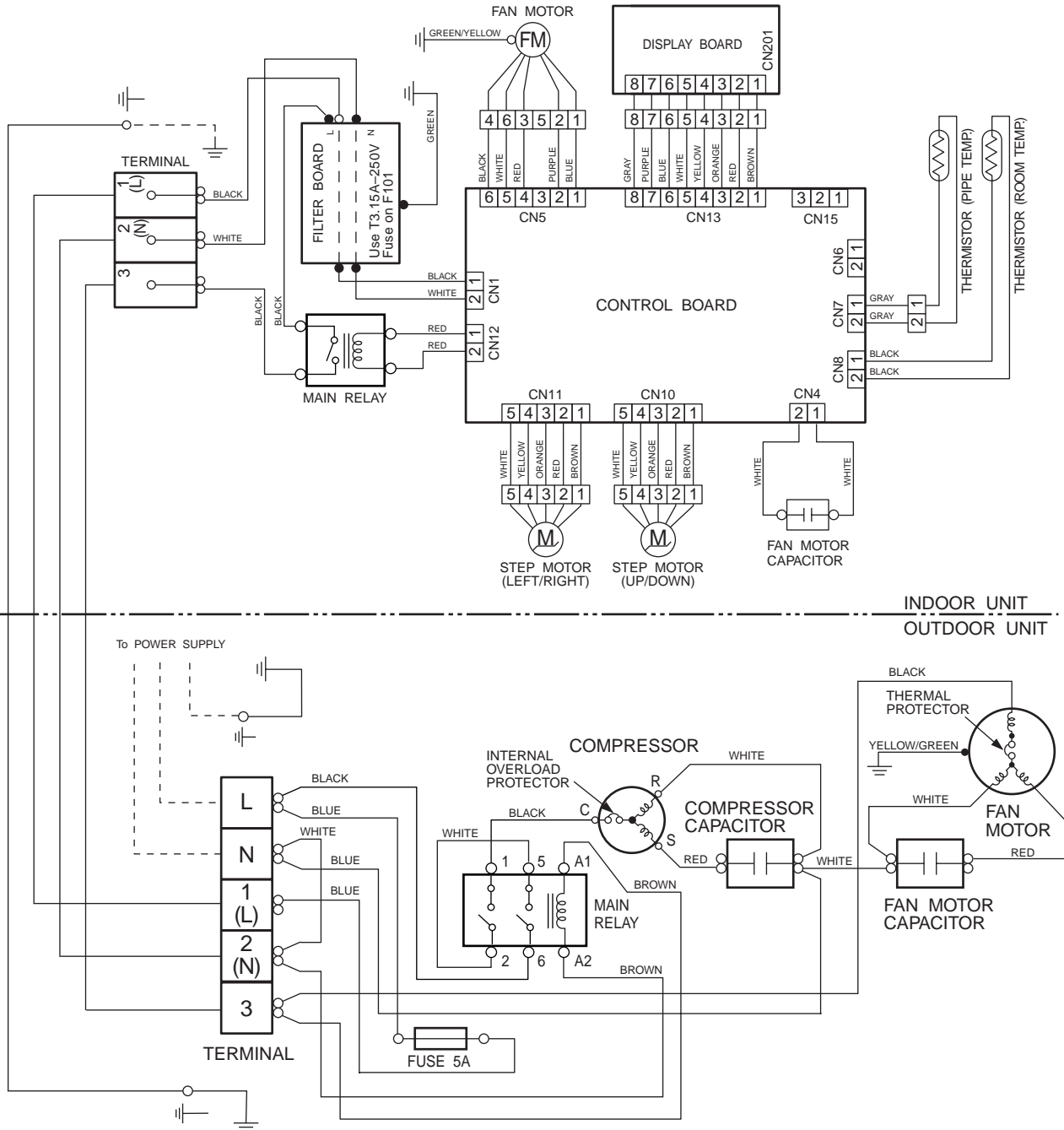

**Models : RYT-18RB / ROW-18RB
RYT-24RE / ROW-24RE**

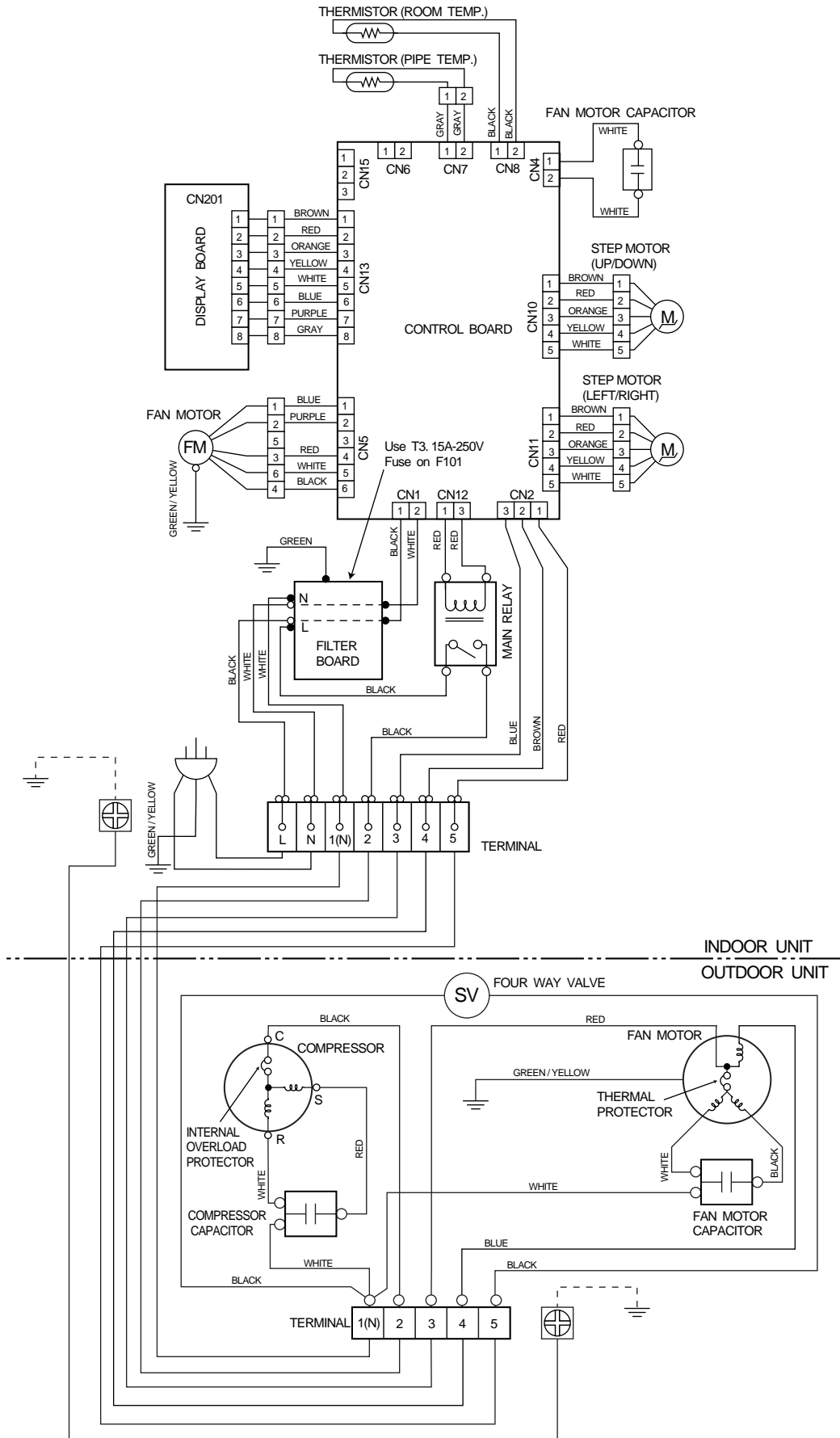

REFRIGERANT SYSTEM DIAGRAM

Models : RYT-14 / ROY-14AA

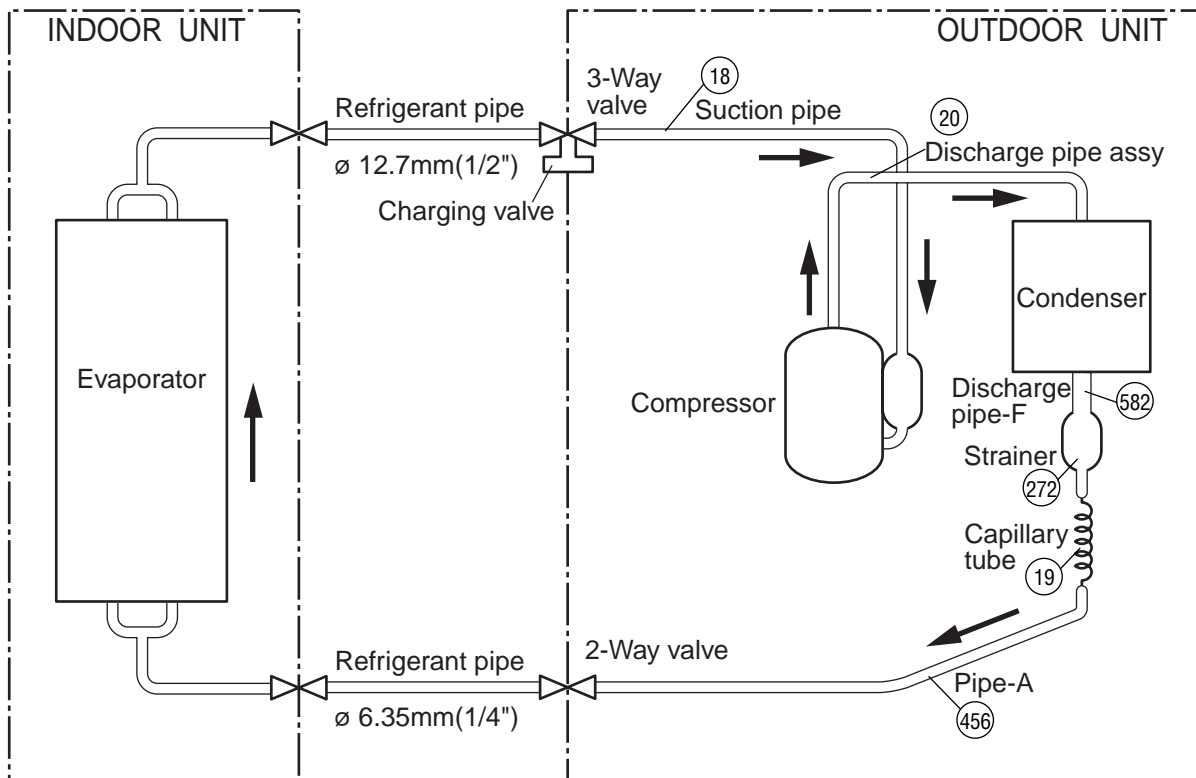

Models : RYT-14R / ROY-14RA

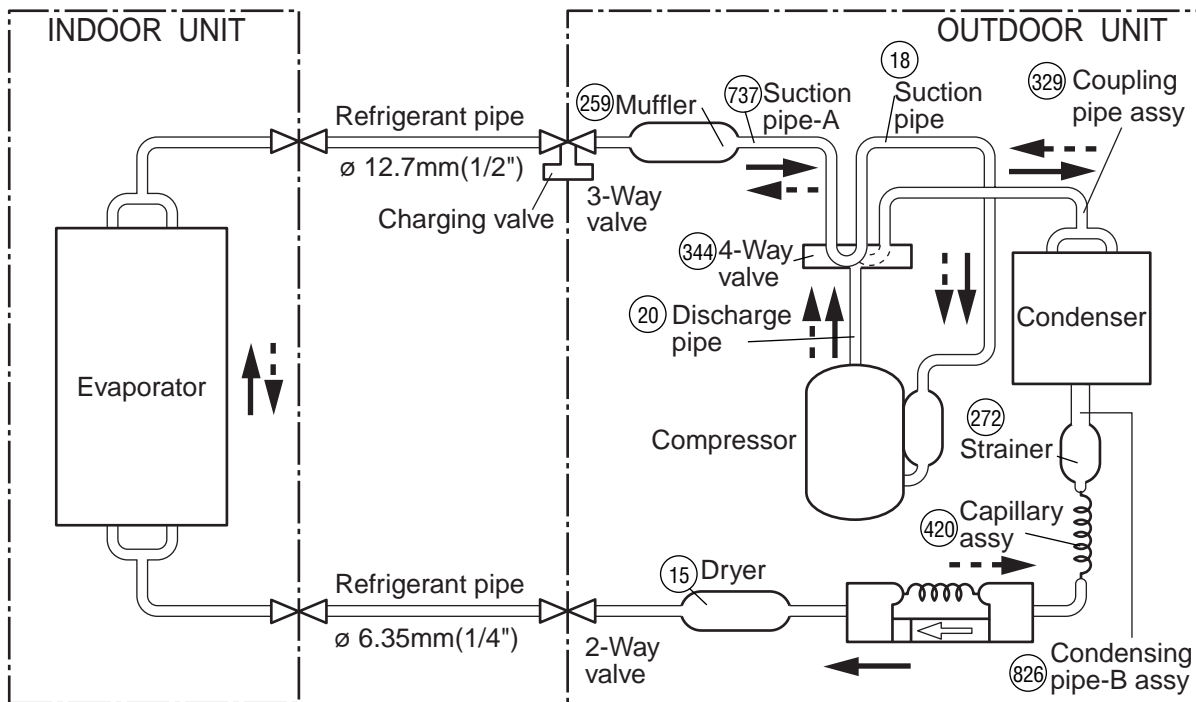

- Cooling
- Heating
- : Flare coupling

Models : RYT-18AC / RO-18AC

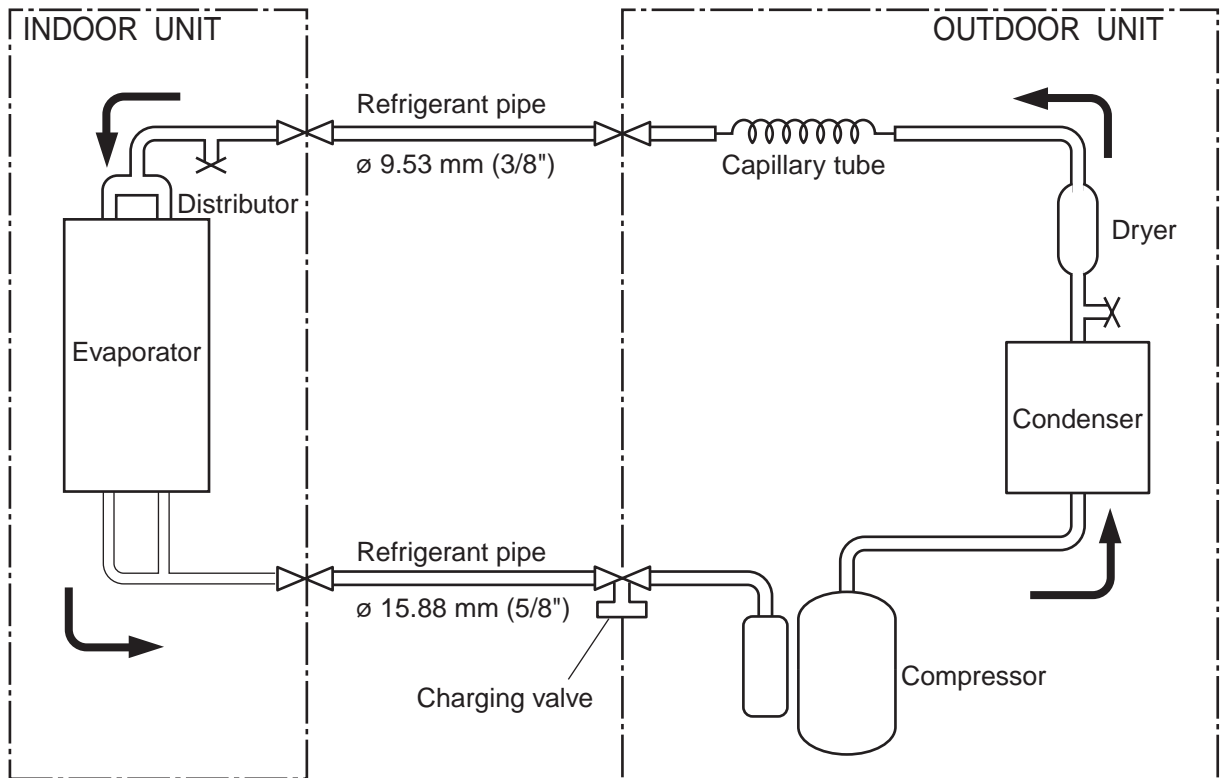

Models : RYT-18RB / ROW-18RB

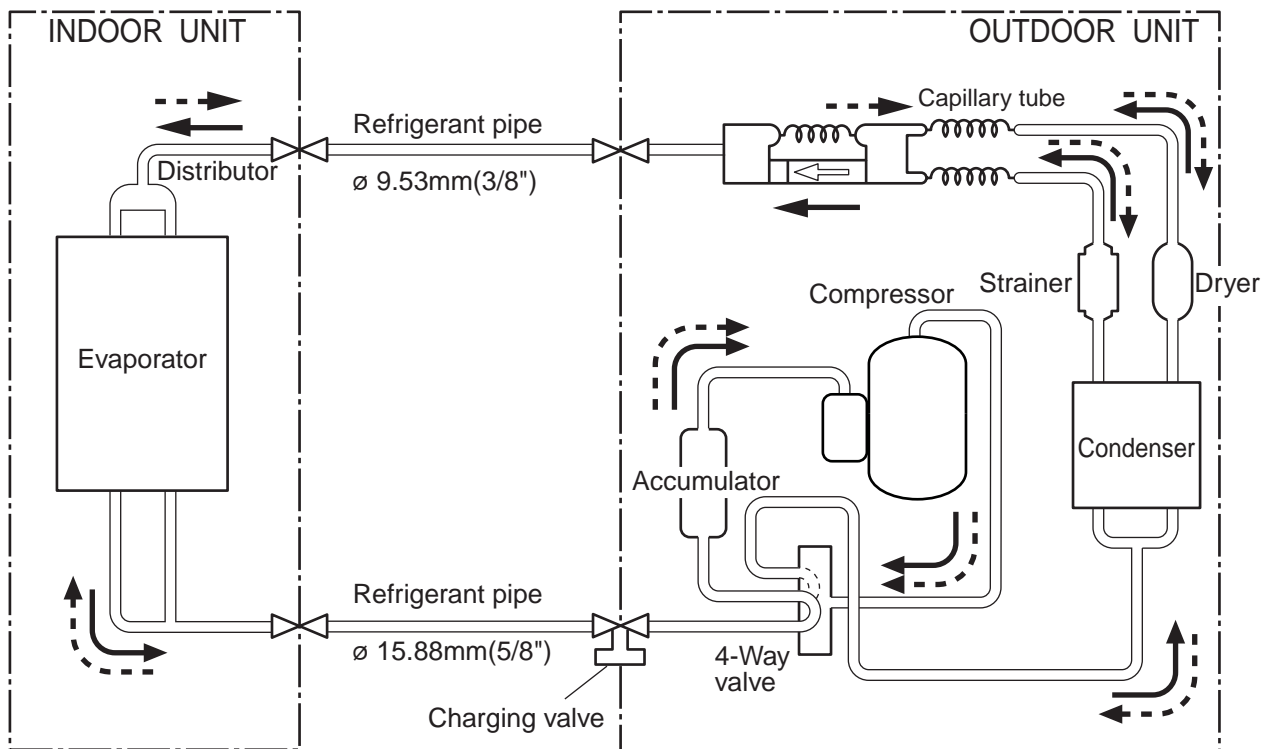

- Cooling
- - - - - Heating
- ⊗ : Flare coupling

Models : RYT-24CA / ROW-24CA

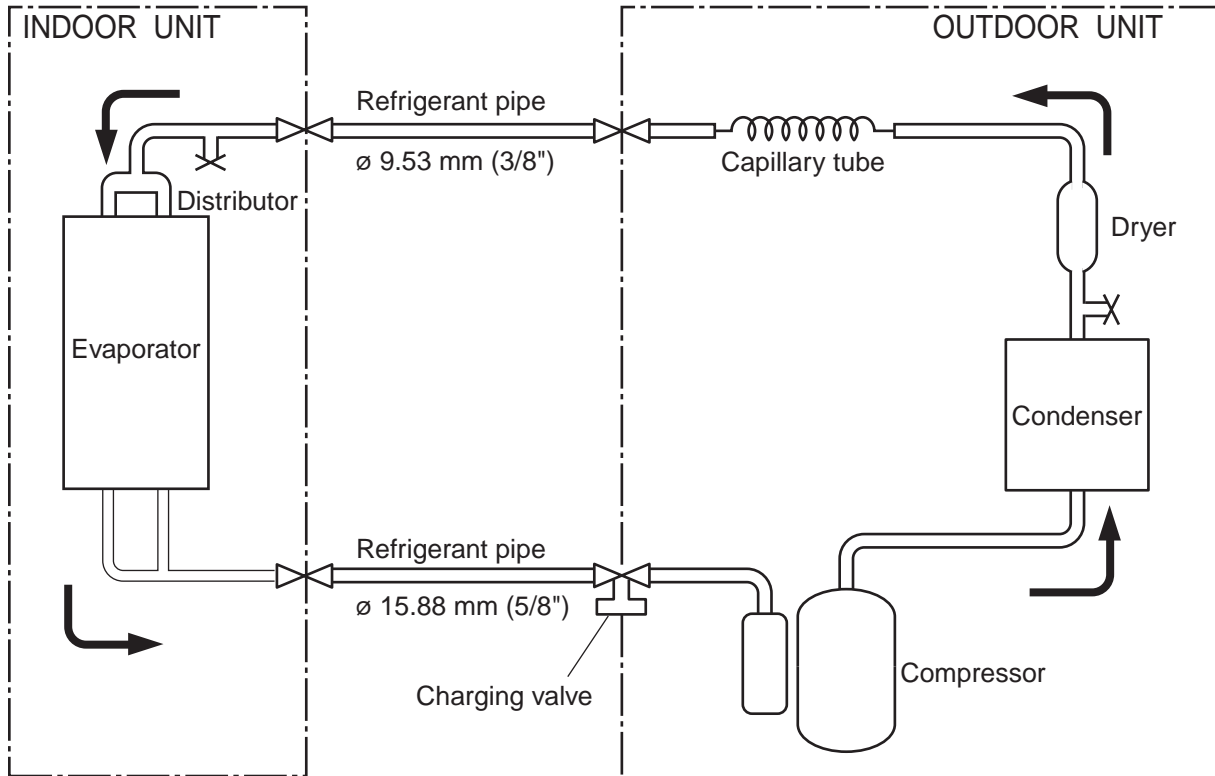

Models : RYT-24RE / ROW-24RE

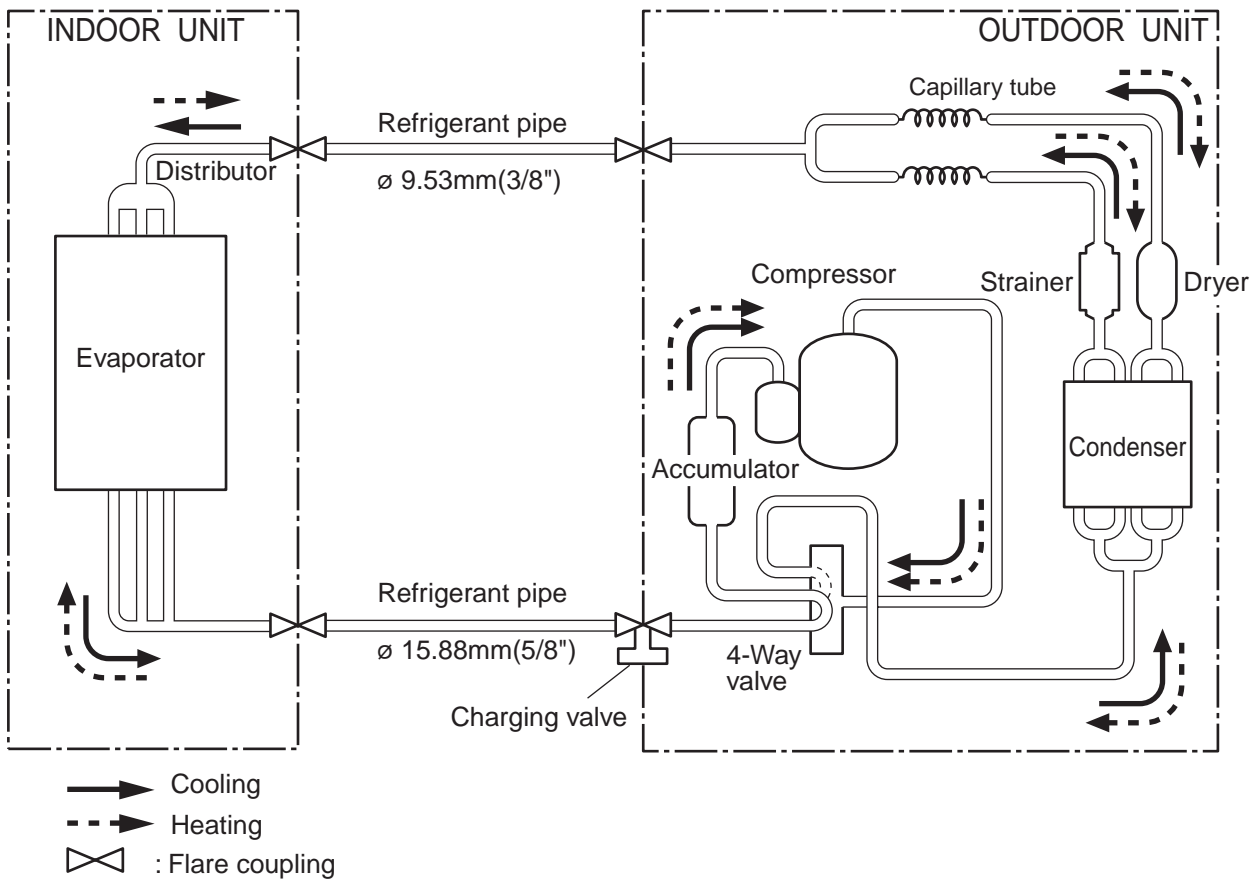

P.C. BOARD LAYOUTS

CONTROLLER PCB ASSEMBLY (MAIN PCB)

(Viewed from the solder side)

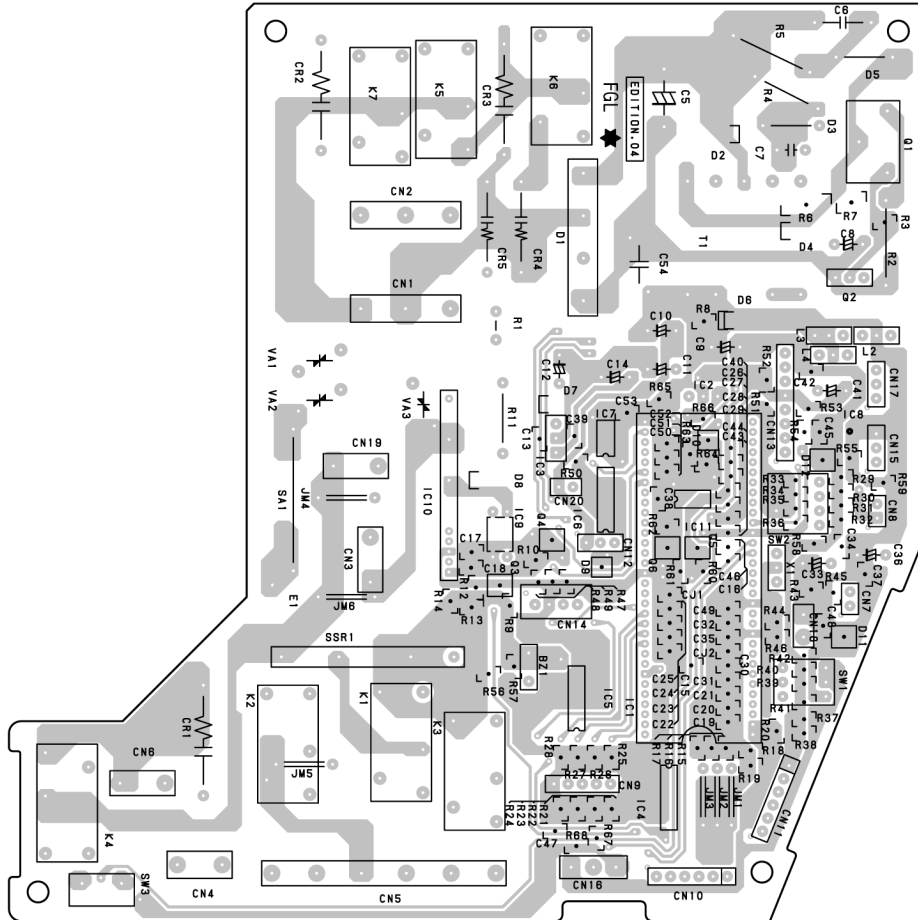

INDICATOR PCB ASSEMBLY

(Viewed from the solder side)

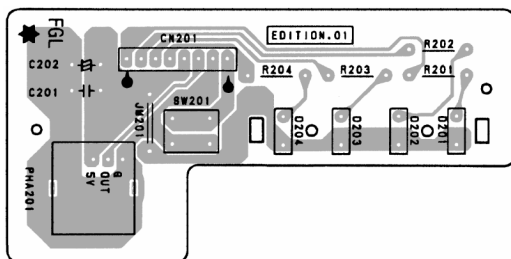

FILTER PCB ASSEMBLY

(Viewed from the solder side)

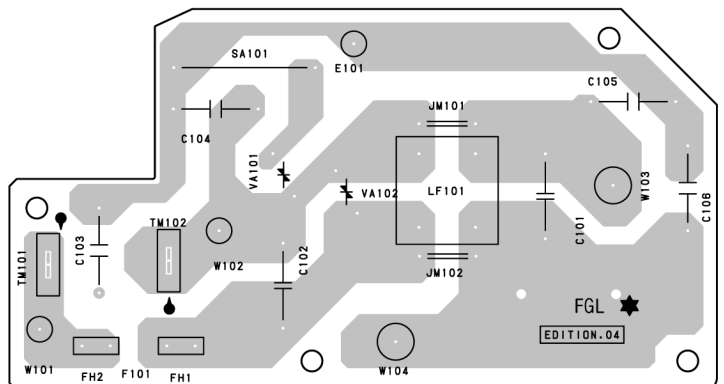

CONTROLLER PCB ASSEMBLY (MAIN PCB)

(Viewed from the component side)

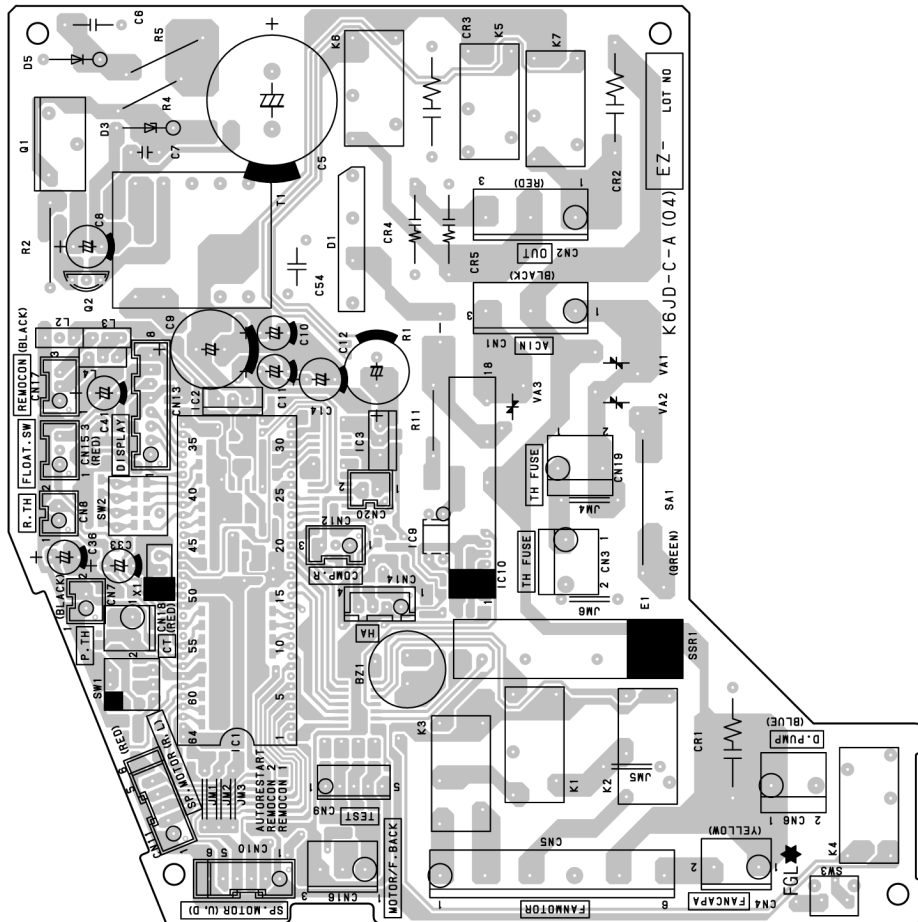

INDICATOR PCB ASSEMBLY

(Viewed from the component side)

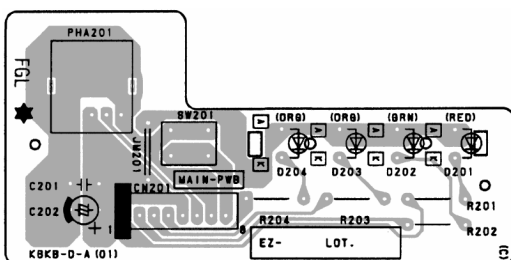

FILTER PCB ASSEMBLY

(Viewed from the component side)

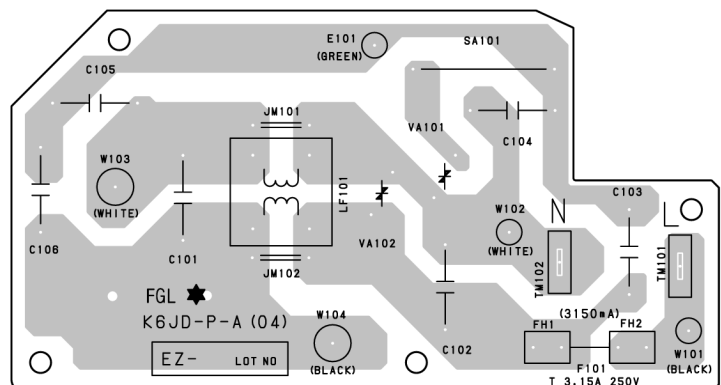

INDOOR PRINTED CIRCUIT BOARD CIRCUIT DIAGRAM

**Models : RYT-14
RYT-18AC
RYT-24CA**

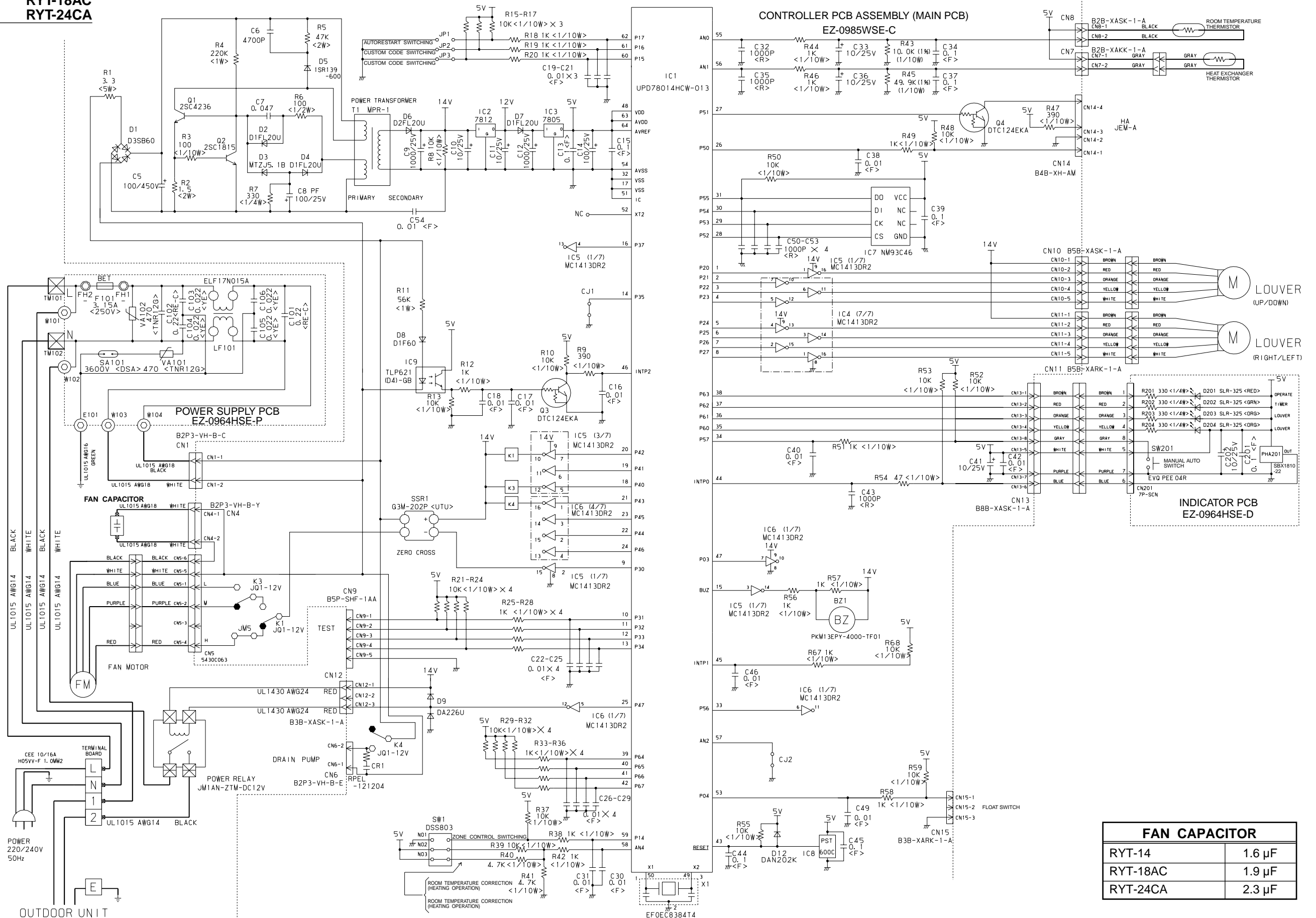

POWER
220/240V
50Hz

OUTDOOR UNIT

FAN CAPACITOR	
RYT-14	1.6 μF
RYT-18AC	1.9 μF
RYT-24CA	2.3 μF

Model : RYT-14R

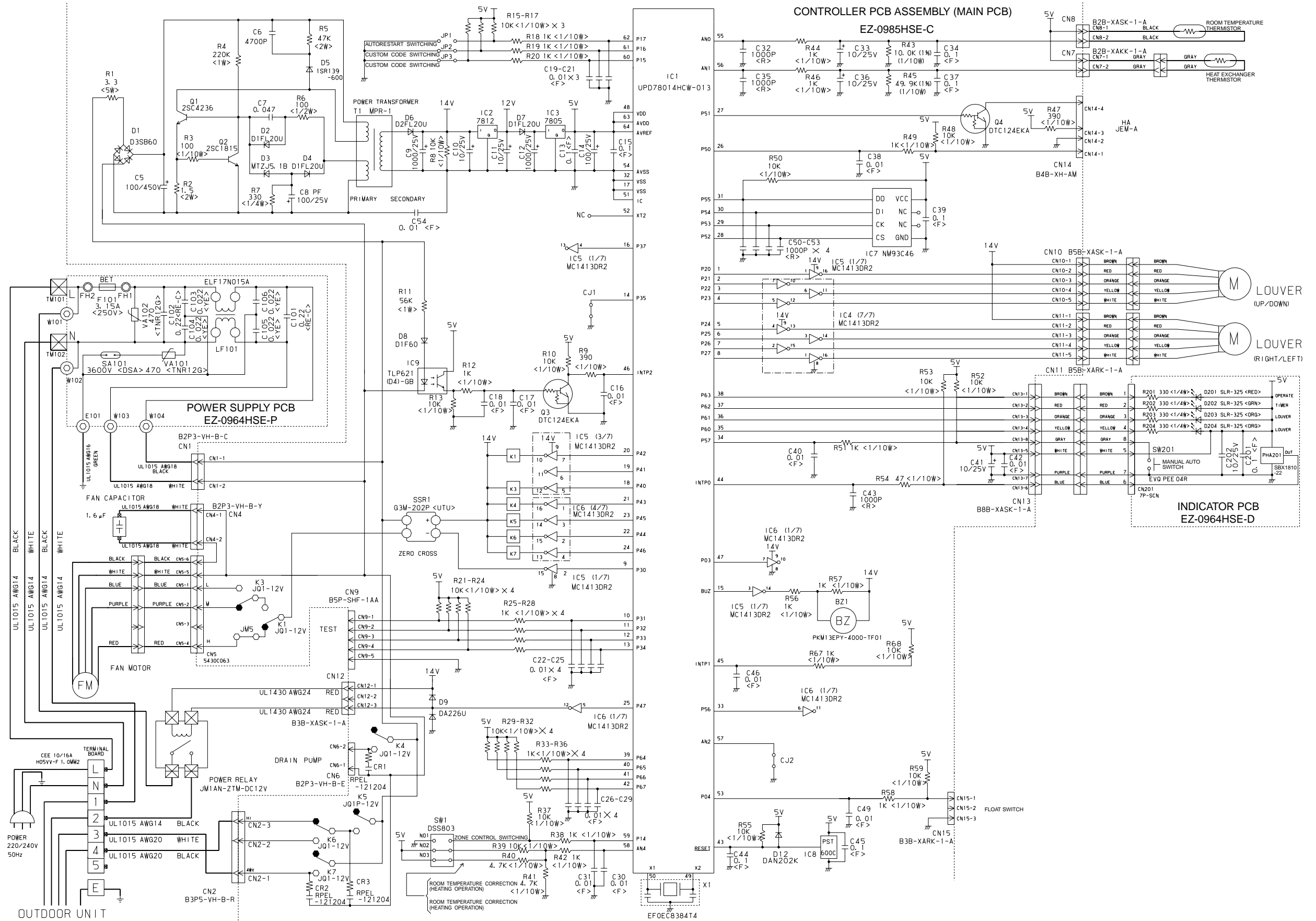

**Models : RYT-18RB
RYT-24RE**

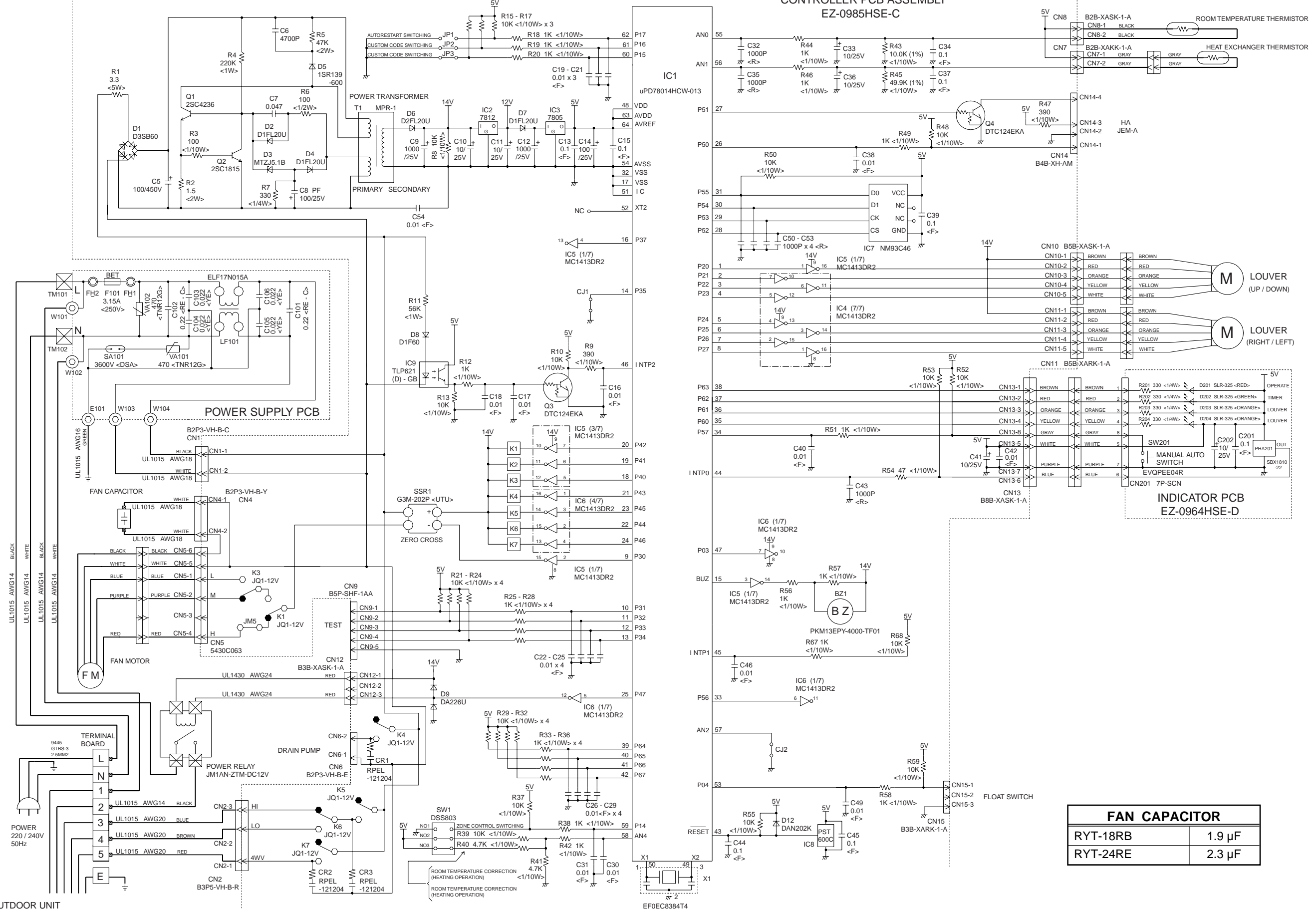

OUTDOOR UNIT

FAN CAPACITOR	
RYT-18RB	1.9 μF
RYT-24RE	2.3 μF

DISASSEMBLY ILLUSTRATION

Models : RYT-14
RYT-14R
RYT-18AC
RYT-18RB
RYT-24CA
RYT-24RE

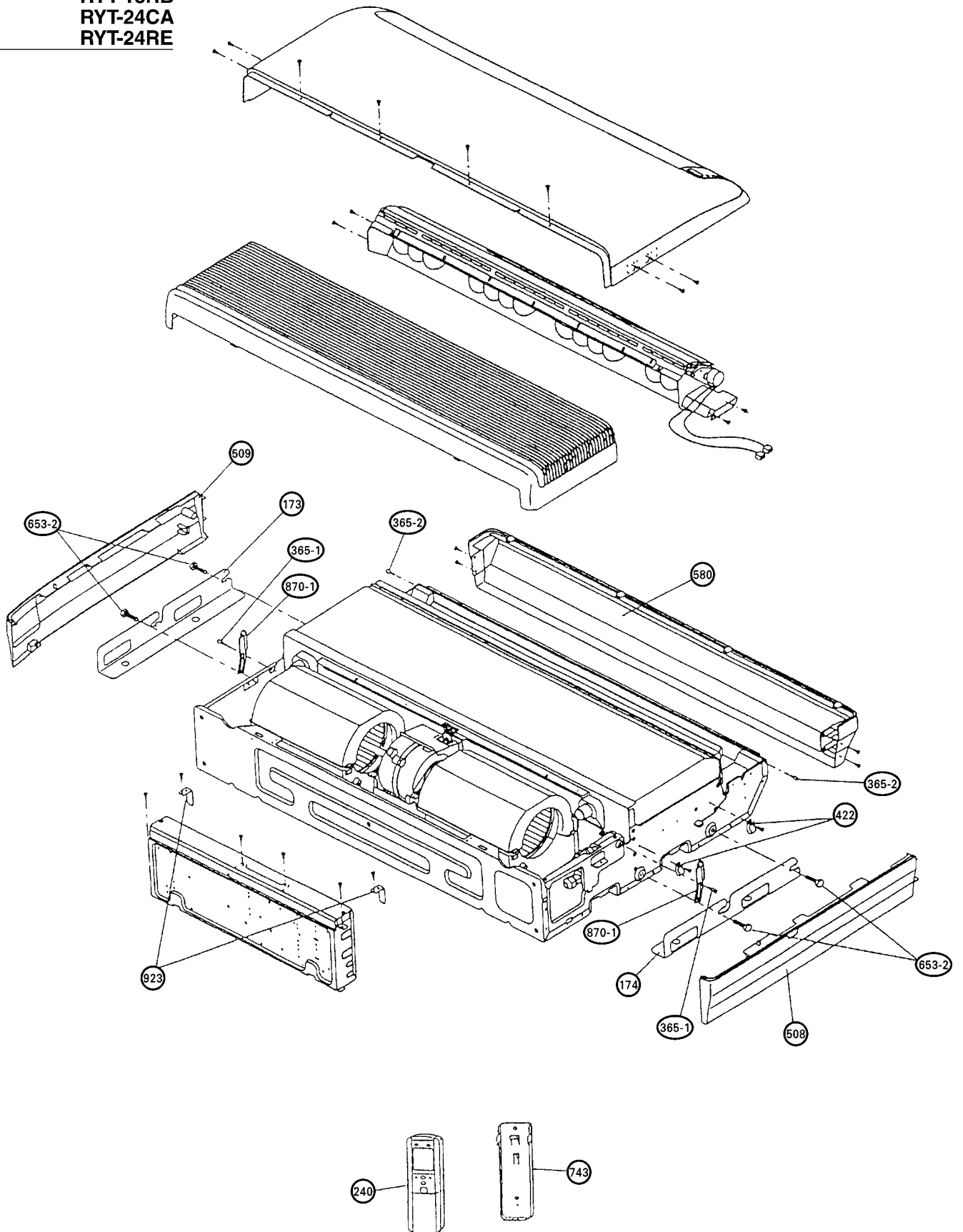

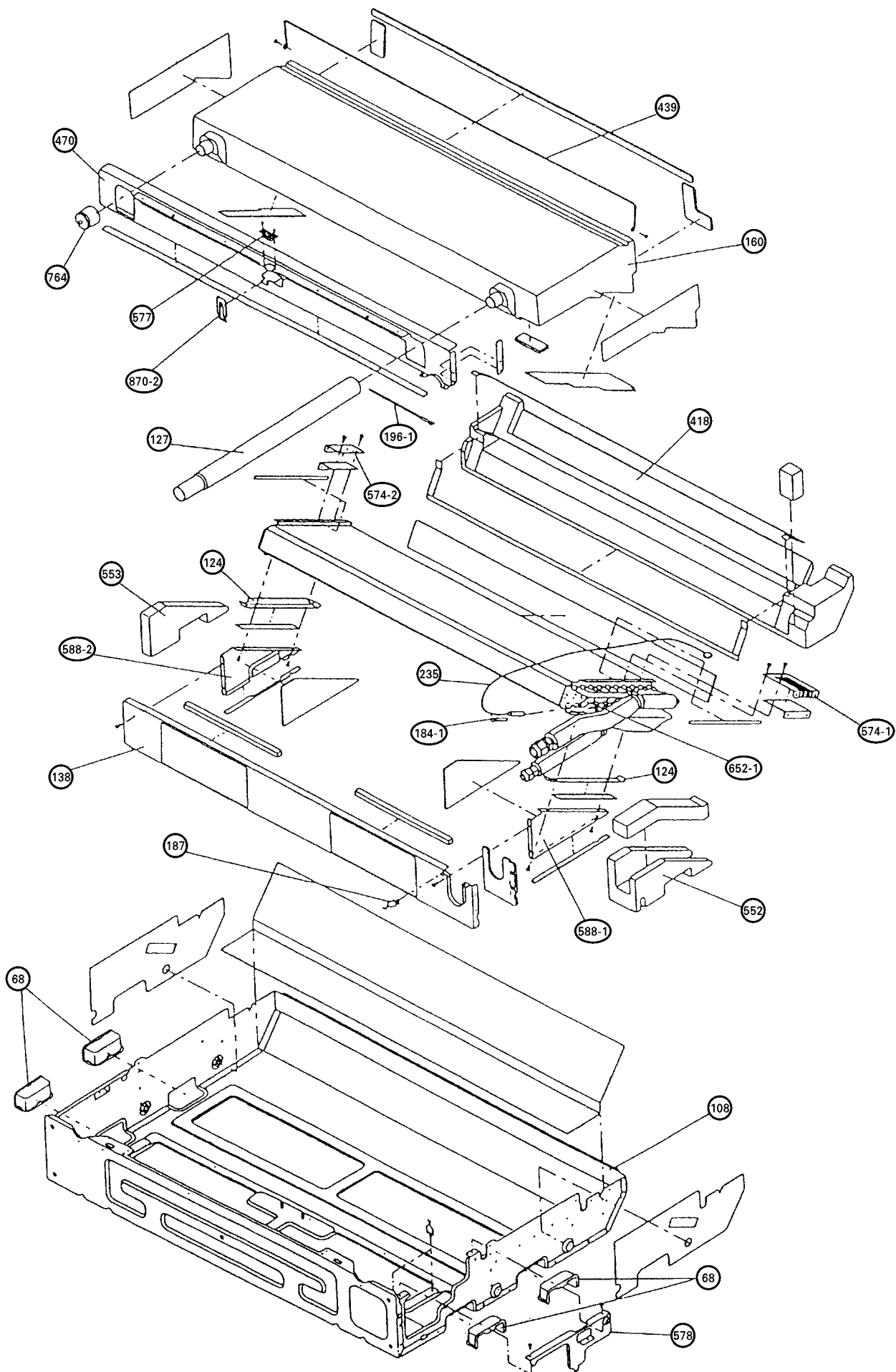

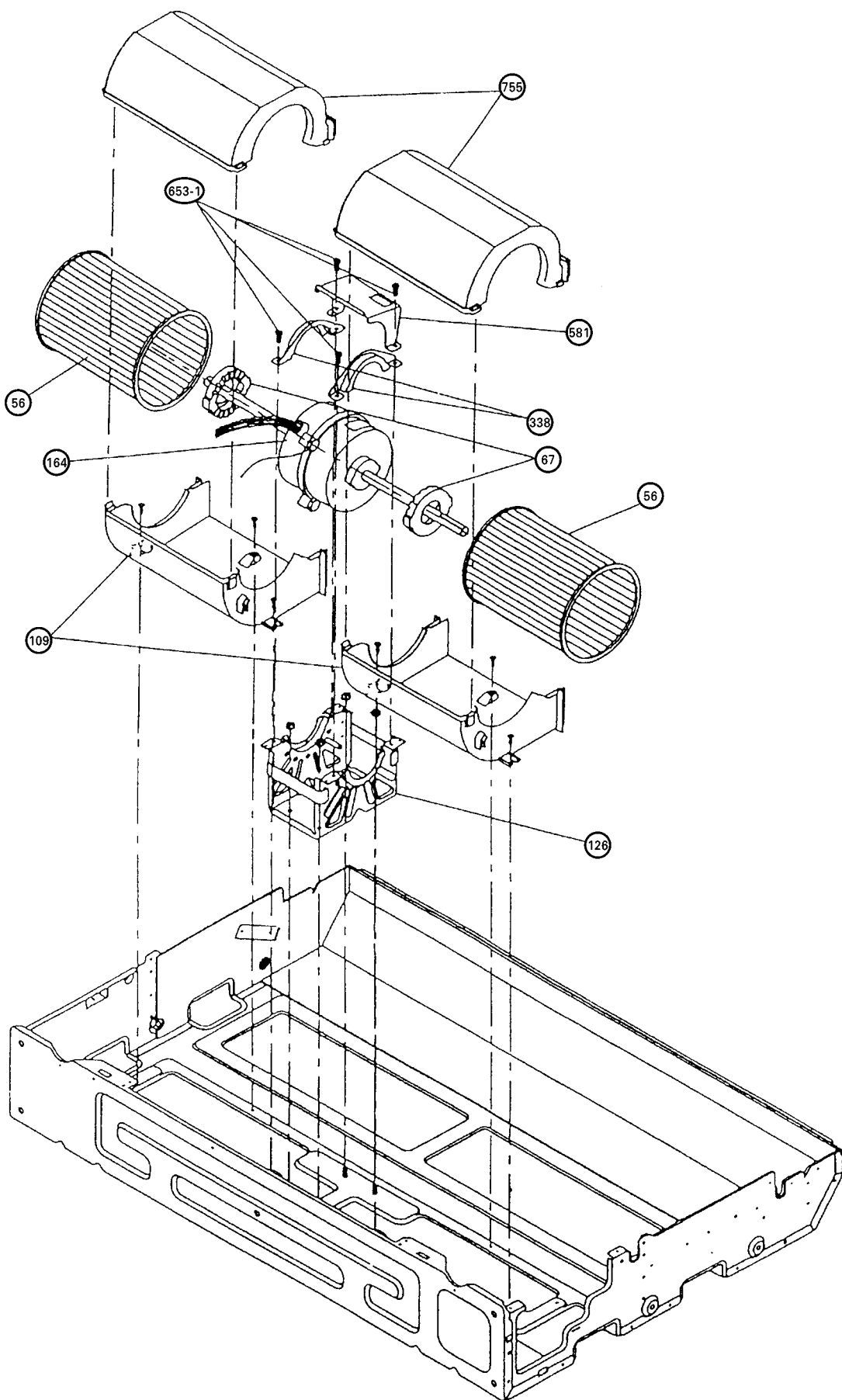

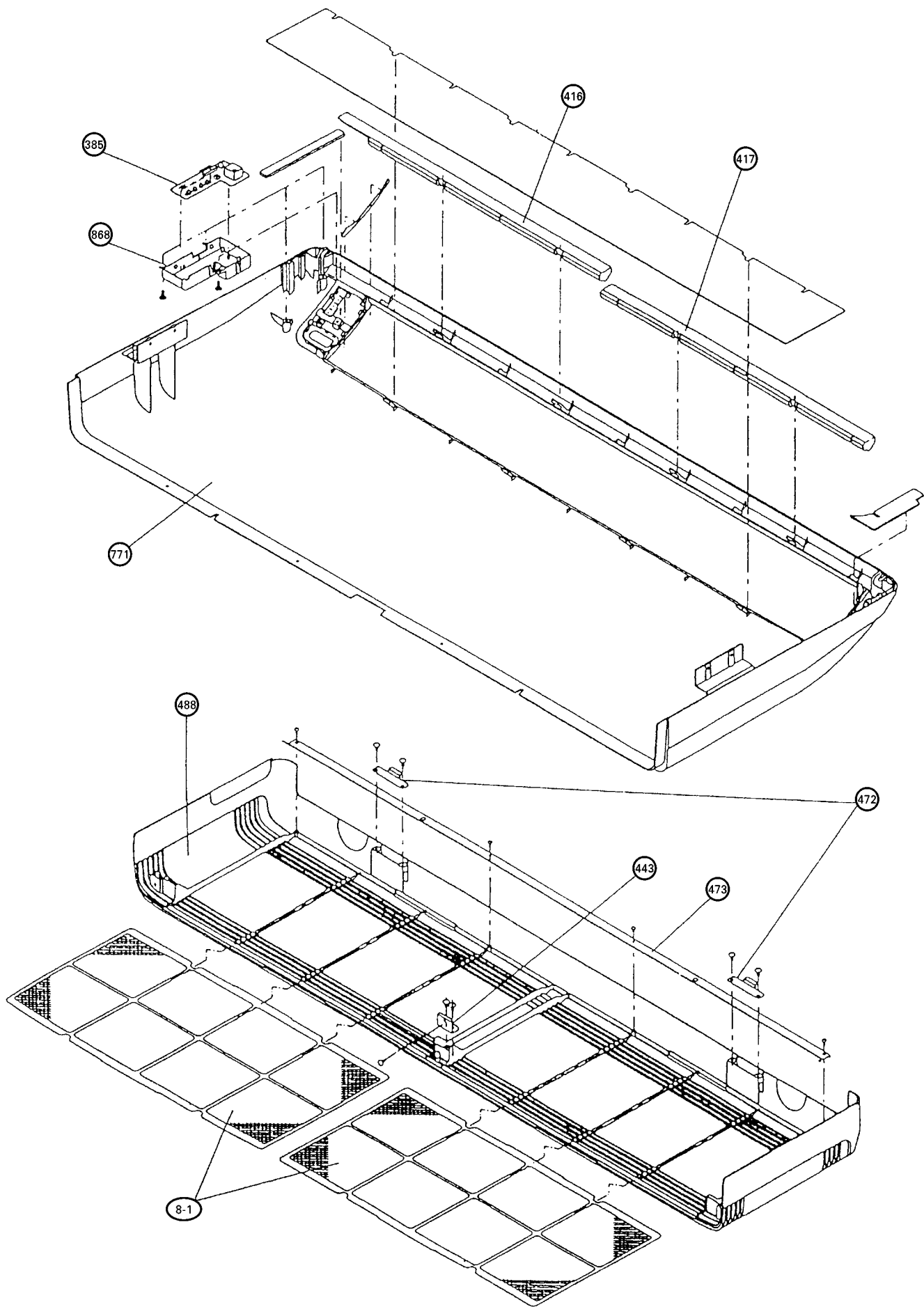

**Models : RYT-14
RYT-14R**

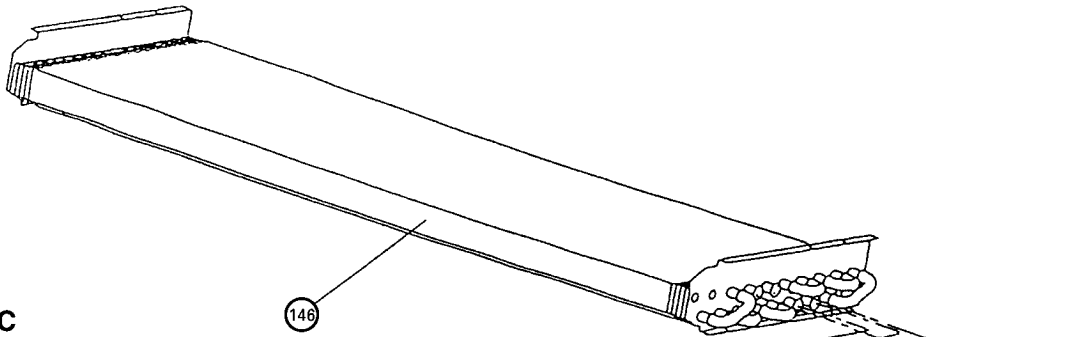

**Models : RYT-18AC
RYT-18RB**

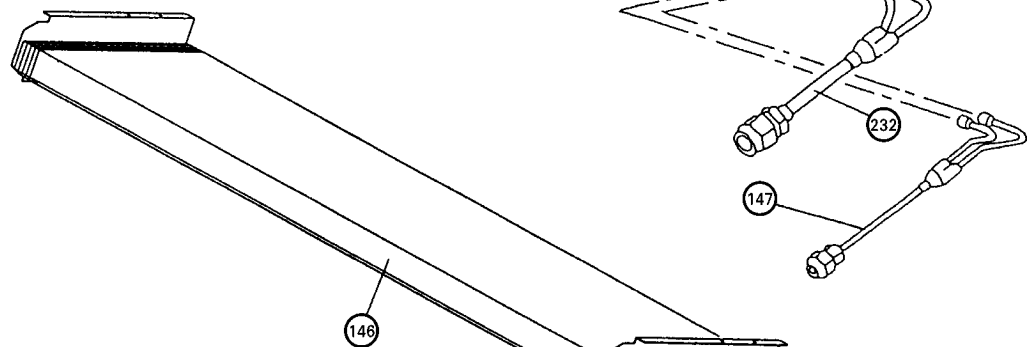

**Models : RYT-24CA
RYT-24RE**

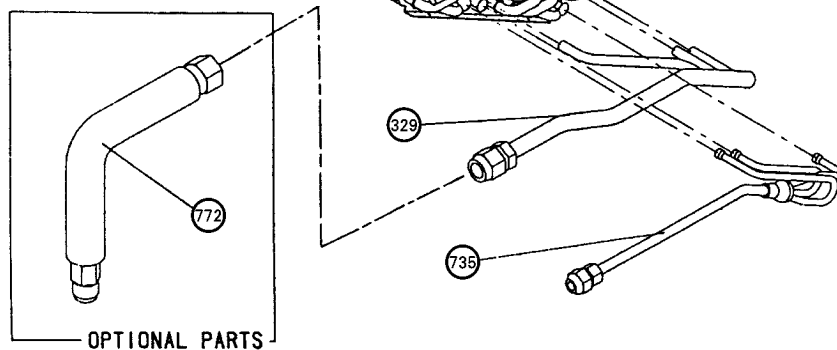
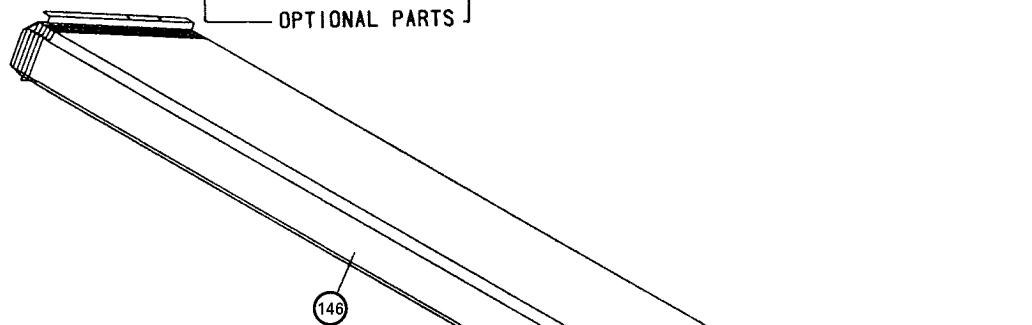
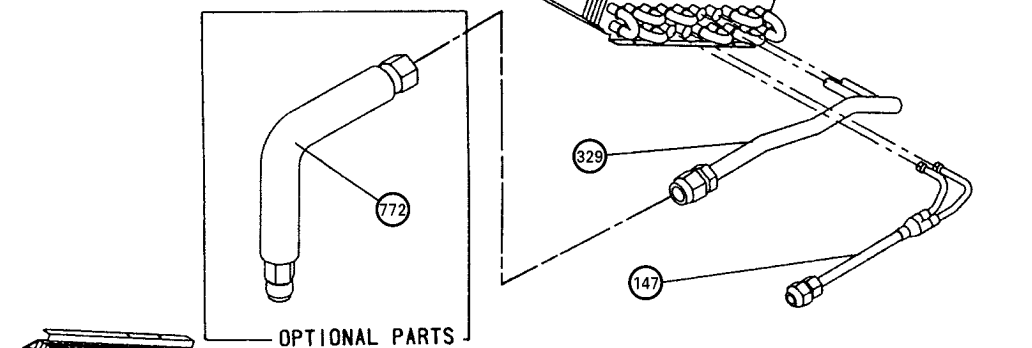

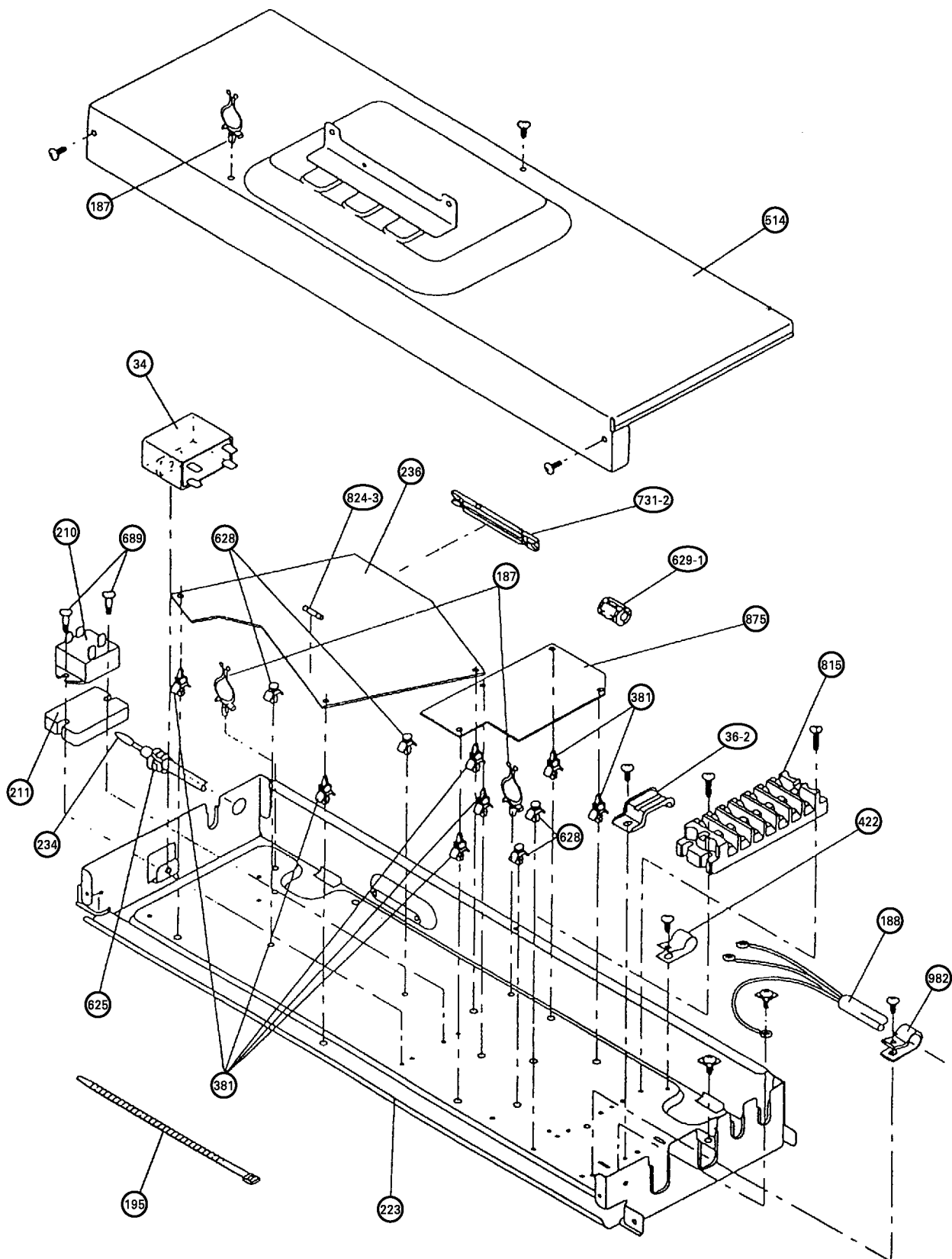

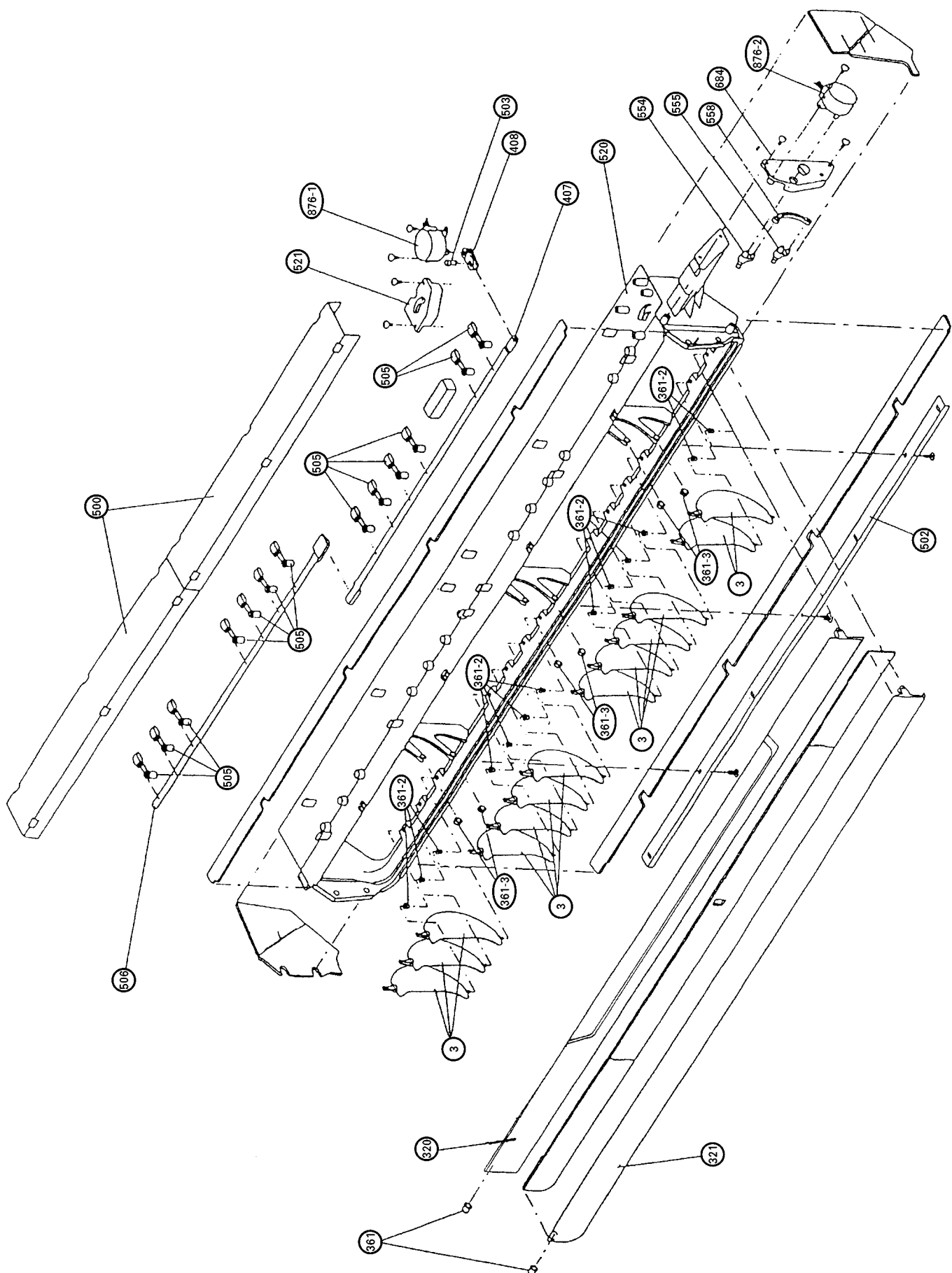

Models : ROY-14AA
ROY-14RA

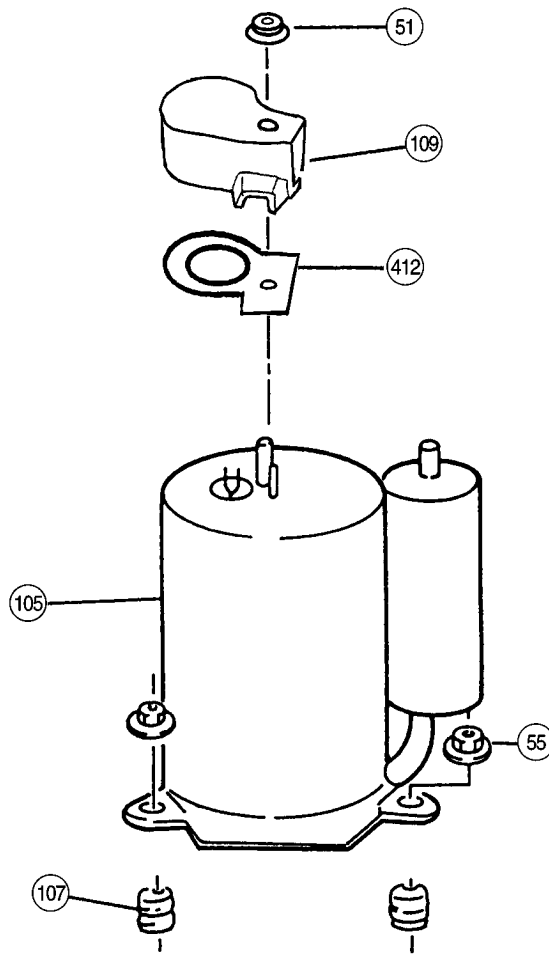

Model : RO-18AC

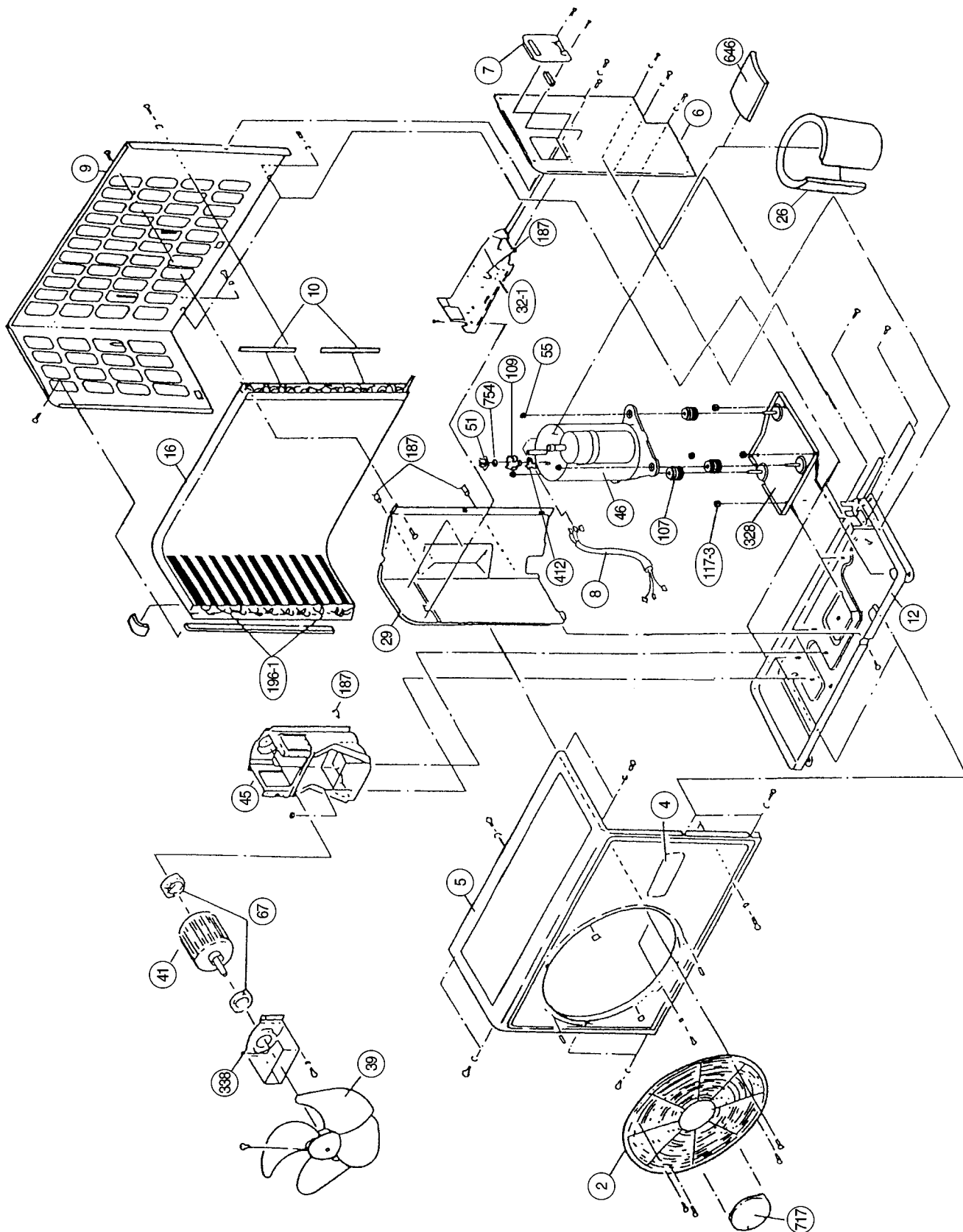

Models : ROW-18RB
ROW-24CA
ROW-24RE

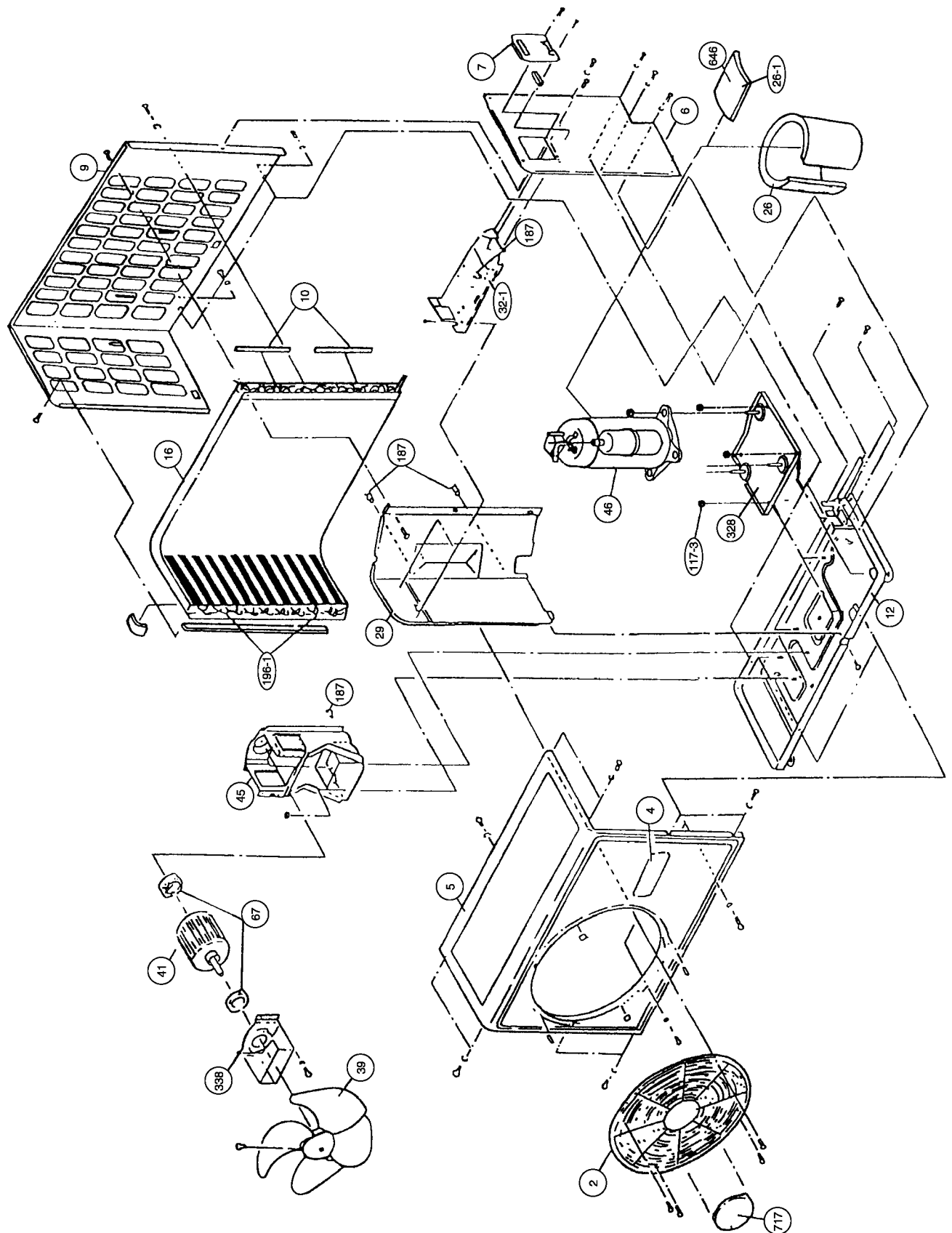

Model : RO-18AC

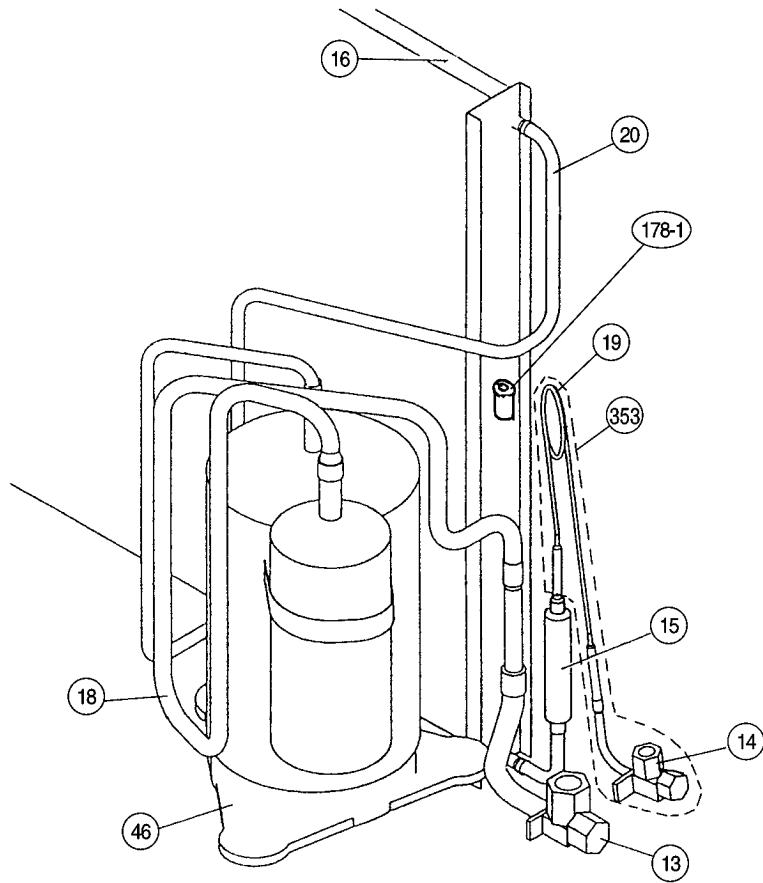

Model : ROW-24CA

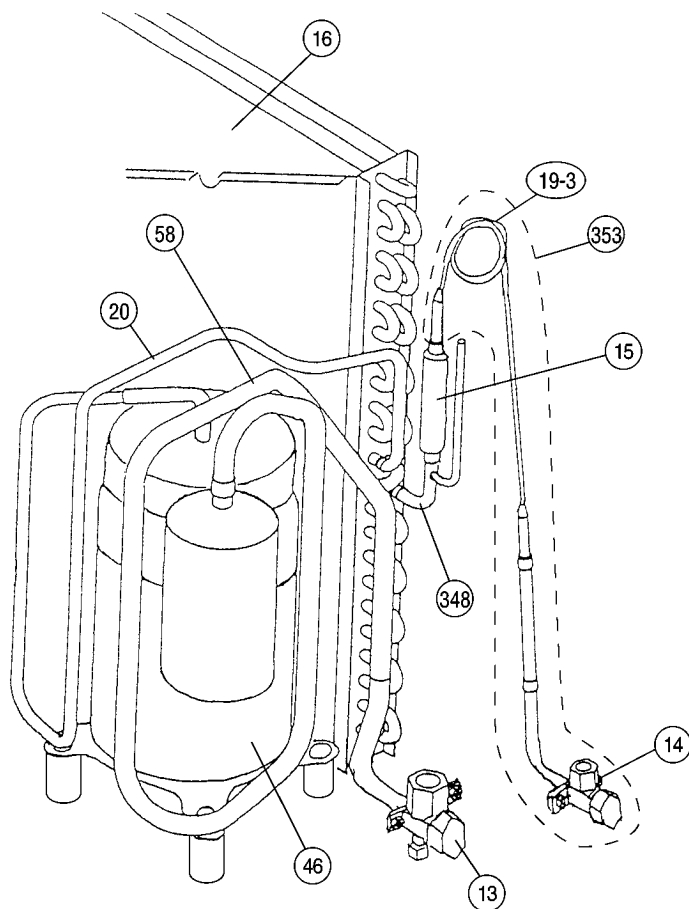

Model : ROW-18RB

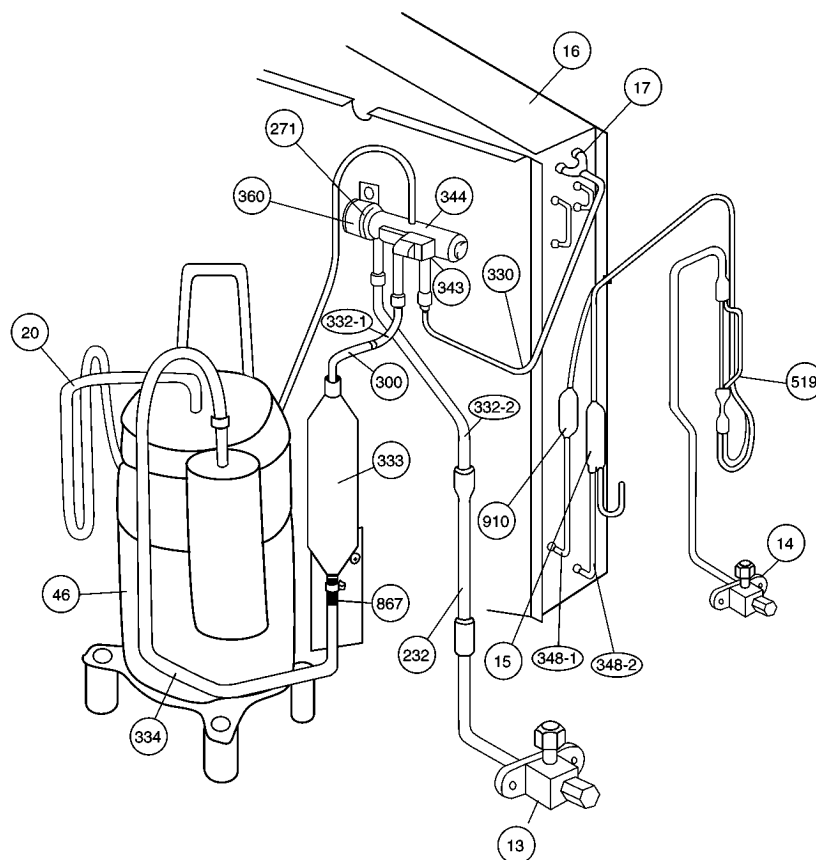

Model : ROW-24RE

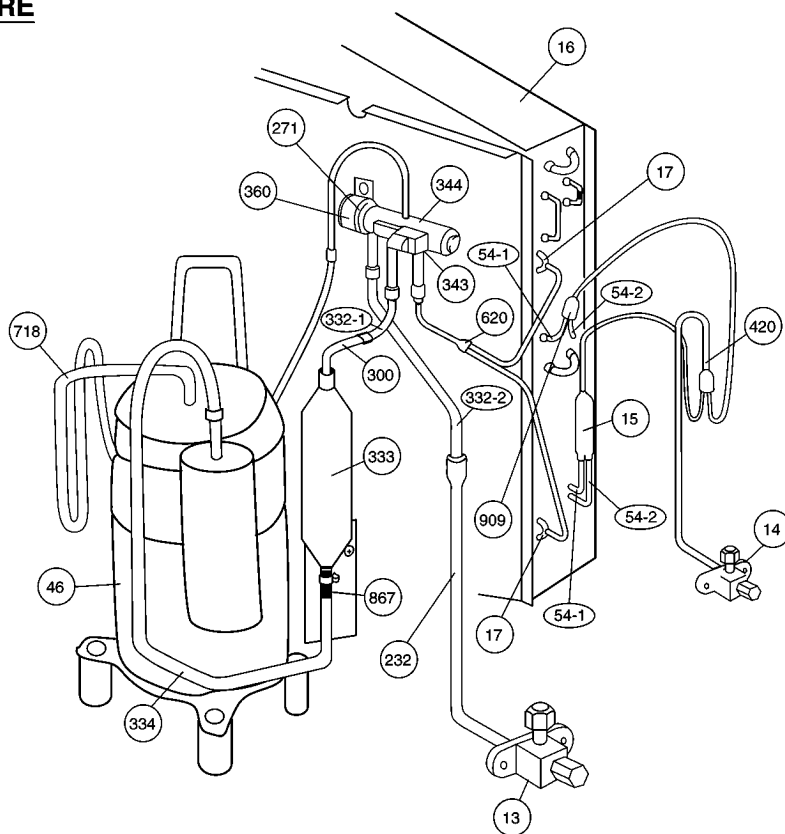

**Models : RO-18AC
ROW-24CA**

Control Unit

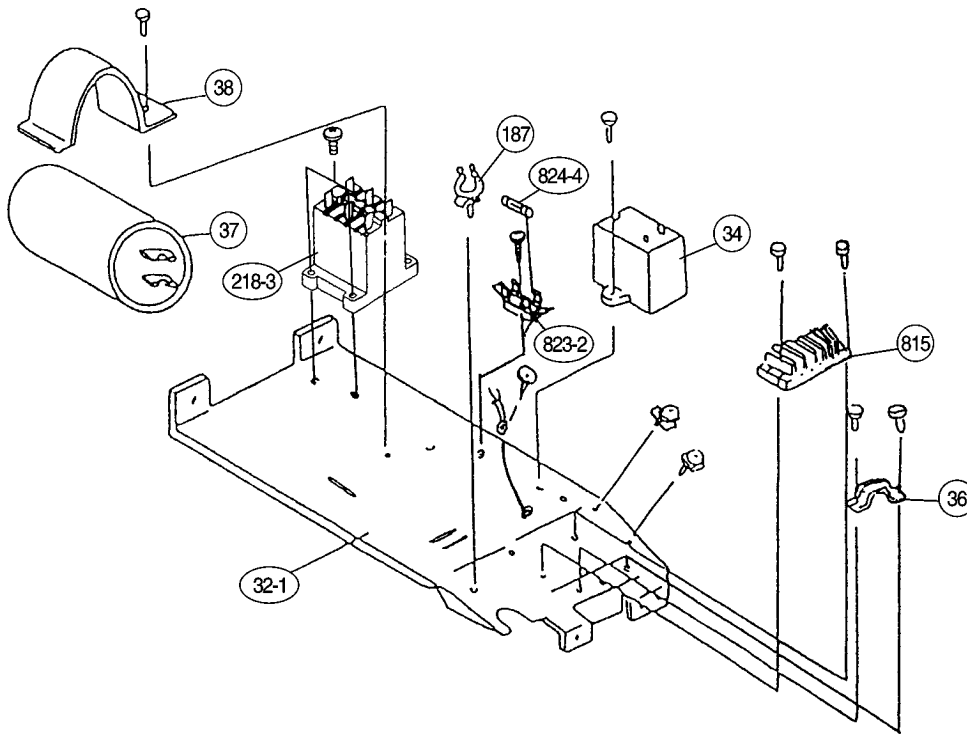

**Models : ROW-18RB
ROW-24RE**

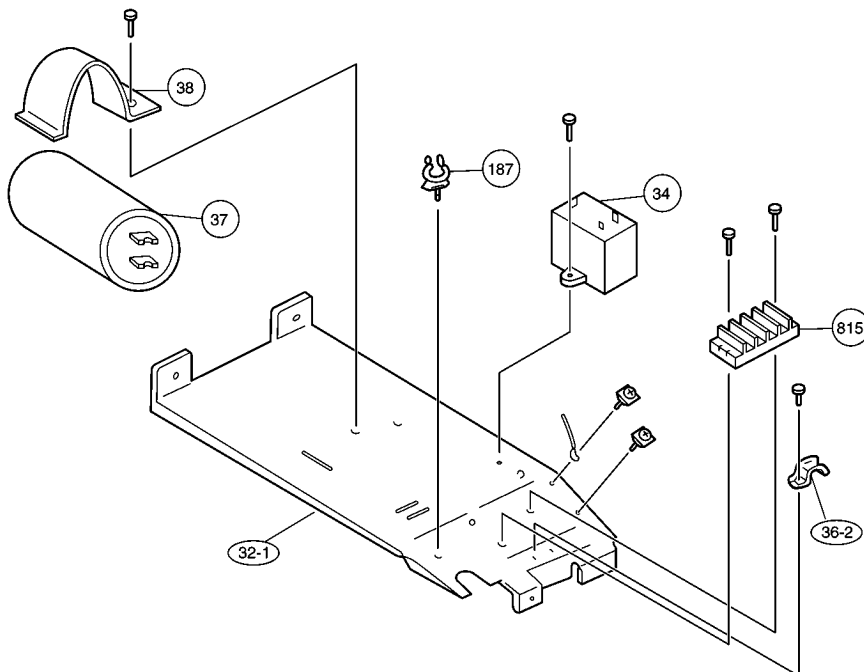

**Models : ROW-18RB
ROW-24CA
ROW-24RE**

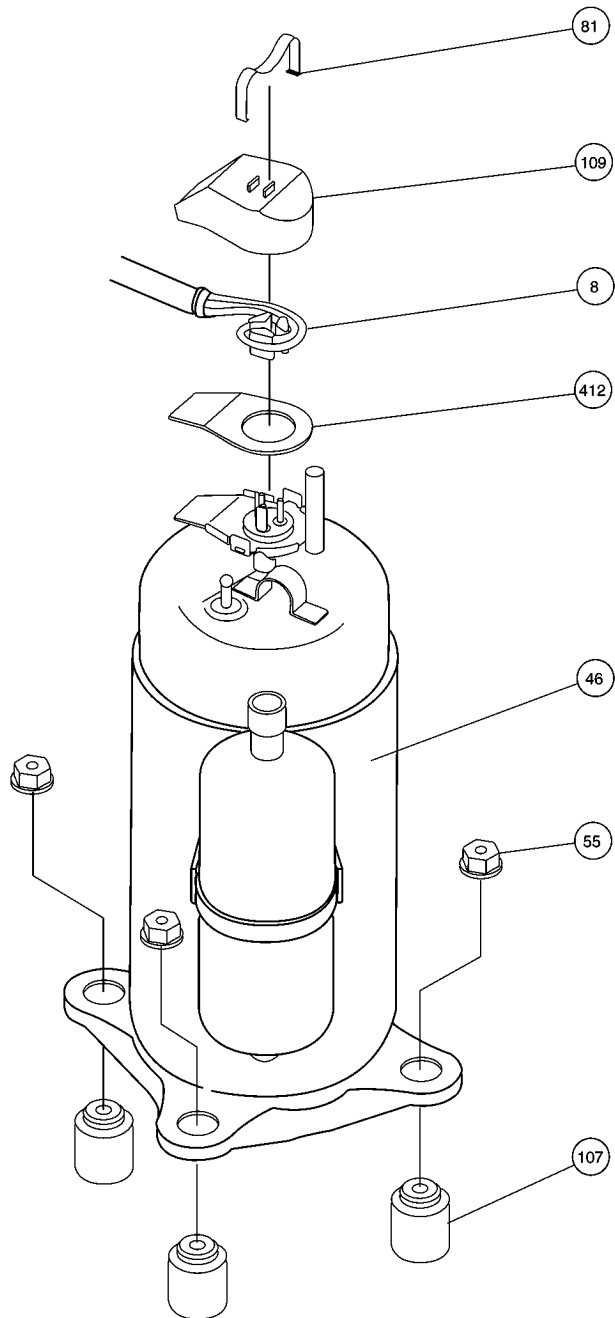

PARTS LIST

INDOOR UNIT

When you order parts, please make a photocopy of this page and fill the number of the parts in the "Order" column.

Ref. No.	Description	Part No.						Ord.
		RYT-14	RYT-14R	RYT-18AC	RYT-18RB	RYT-24CA	RYT-24RE	Q'ty
3	Louver	9358561010	9358561010	9358561010	9358561010	9358561010	9358561010	
8-1	Air Filter	9358567029	9358567029	9358567029	9358567029	9358567029	9358567029	
34	Capacitor (Fan Motor) 1.9µF/350V	—	—	9703306099	9703306099	—	—	
34	Capacitor (Fan Motor) 2.3µF/450V	—	—	—	—	9703306044	9703306044	
34	Capacitor (Fan Motor) 1.6µF/400V	9704305039	9704305039	—	—	—	—	
36-2	Cord Holder Metal	9356362008	9356362008	9356362008	9356362008	9356362008	9356362008	
56	Sirocco Fan Assy	9358621004	9358621004	9358621004	9358621004	9358621004	9358621004	
67	Rubber (Vibration-proof)	313659068604	313659068604	313659068604	313659068604	313659068604	313659068604	
68	Cap, Plastic	9358563007	9358563007	9358563007	9358563007	9358563007	9358563007	
108	Base Assy	9359061014	9359061014	9359061014	9359061014	9359061014	9359061014	
109	Casing, Plastic	9358543009	9358543009	9358543009	9358543009	9358543009	9358543009	
124	Dew Proof Plate	9359196006	9359196006	9359196006	9359196006	9359196006	9359196006	
126	Motor Fixing Table Assy	9358591000	9358591000	9358591000	9358591000	9358591000	9358591000	
127	Drain Hose Assy	9359242000	9359242000	9359242000	9359242000	9359242000	9359242000	
138	Separate Wall-A	9358584002	9358584002	9358584002	9358584002	9358584002	9358584002	
146	Evaporator Assy C688E	—	—	—	—	9358870013	9358870013	
146	Evaporator Assy C695E	—	—	9365770009	9359310013	—	—	
146	Evaporator Assy D516E	9359379003	9359379003	—	—	—	—	
147	Inlet Pipe (Eva.) Assy, Welded	9359370000	9359370000	9365769003	9359263005	—	—	
160	Drain Pan Assy	9358568002	9358568002	9358568002	9358568002	9358568002	9358568002	
164	Fan Motor Assy-IN MFA-24CTAT	—	—	—	—	9600778043	9600778043	
164	Fan Motor Assy-IN MFA-18CTT	—	—	9600778029	9600778029	—	—	
164	Fan Motor Assy-IN MFA-14CTT	9600778012	9600778012	—	—	—	—	
173	Hanger Bracket-L	9358596005	9358596005	9358596005	9358596005	9358596005	9358596005	
174	Hanger Bracket-R	9358595008	9358595008	9358595008	9358595008	9358595008	9358595008	
184-1	Thermistor Spring-A	313728262708	313728262708	313728262708	313728262708	313728262708	313728262708	
187	Clamp No. 1219	313361271706	313361271706	313361271706	313361271706	313361271706	313361271706	
188	Power Cord Assy	9900017019	9900017019	—	—	9360713025	9360713025	
195	Clamp SKB-100	313361275805	313361275805	313361275805	313361275805	313361275805	313361275805	
196-1	Clamp SKB-3M	312300787605	312300787605	312300787605	312300787605	312300787605	312300787605	
210	Main Relay	9356781007	9356781007	9356781007	9353611017	9356781007	9353611017	
211	Cushion Rubber	313806328306	313806328306	313806328306	313806328306	313806328306	313806328306	
223	Control Box	9358600016	9358600016	9358600016	9358600016	9358600016	9358600016	
232	Outlet Pipe (Evaporator) Assy	9359374008	9359374008	—	—	—	—	
234	Thermistor Assy	9703299025	9703299025	9703299025	9703299025	9703299025	9703299025	
235	Thermistor Assy-Pipe	9701102068	9701102068	9701102068	9701102068	9701102068	9701102068	
236	Controller PCB Assy EZ-0964HSE-C	—	—	—	9701941087	—	9701941087	
236	Controller PCB Assy EZ-096VWSE-C	9701941094	—	9701941094	—	9701941094	—	
236	Controller PCB Assy EZ-0975HSE-C	—	9701941124	—	—	—	—	
240	Remote Control Unit AR-DL5	—	9359913054	—	9359913054	—	9359913054	
240	Remote Control Unit AR-DL6	9359913061	—	9359913061	—	9359913061	—	
320	Flap (Upper)-O	9358540015	9358540015	9358540015	9358540015	9358540015	9358540015	
321	Flap (Lower)	9358541012	9358541012	9358541012	9358541012	9358541012	9358541012	
329	Coupling Pipe Assy	—	—	9365771006	9359267003	9358819005	9358819005	
338	Motor Fixture	9358594001	9358594001	9358594001	9358594001	9358594001	9358594001	
361	Bushing	9357942001	9357942001	9357942001	9357942001	9357942001	9357942001	
361-2	Bushing-B, Plastic	9358554005	9358554005	9358554005	9358554005	9358554005	9358554005	
361-3	Bushing-C, Plastic	9358553008	9358553008	9358553008	9358553008	9358553008	9358553008	
365-1	Special Screw	9359092001	9359092001	9359092001	9359092001	9359092001	9359092001	
365-2	Special Screw	9359091004	9359091004	9359091004	9359091004	9359091004	9359091004	
381	Locking Spacer, KGLS-4S	313209391506	313209391506	313209391506	313209391506	313209391506	313209391506	
385	Indicator PCB Assy EZ-0964HSE-D	9701873012	9701873012	9701873012	9701873012	9701873012	9701873012	
407	Motor Rod	9358560006	9358560006	9358560006	9358560006	9358560006	9358560006	
408	Louver Link	9358556009	9358556009	9358556009	9358556009	9358556009	9358556009	
416	Insulation (Panel)-A	9358574003	9358574003	9358574003	9358574003	9358574003	9358574003	
417	Insulation (Panel)-B	9358914007	9358914007	9358914007	9358914007	9358914007	9358914007	
418	Insulation (Flap Base)	9358572009	9358572009	9358572009	9358572009	9358572009	9358572009	
422	Clamp NK-10N	9359183006	9359183006	9359183006	9359183006	9359183006	9359183006	
439	Drain Pan Wire	9358598009	9358598009	9358598009	9358598009	9358598009	9358598009	
443	Arm Bracket	9359281009	9359281009	9359281009	9359281009	9359281009	9359281009	

INDOOR UNIT (Continued)

When you order parts, please make a photocopy of this page and fill the number of the parts in the "Order" column.

Ref. No.	Description	Part No.						Ord.
		RYT-14	RYT-14R	RYT-18AC	RYT-18RB	RYT-24CA	RYT-24RE	Q'ty
470	Separate Wall-B	9358585009	9358585009	9358585009	9358585009	9358585009	9358585009	
472	Grille Support	9358602003	9358602003	9358602003	9358602003	9358602003	9358602003	
473	Filter Bracket	9358607008	9358607008	9358607008	9358607008	9358607008	9358607008	
488	Grill-G	9358533017	9358533017	9358533017	9358533017	9358533017	9358533017	
500	Protect Cover	9358564004	9358564004	9358564004	9358564004	9358564004	9358564004	
502	Support Stay	9358599006	9358599006	9358599006	9358599006	9358599006	9358599006	
503	Louver Shaft	9358557006	9358557006	9358557006	9358557006	9358557006	9358557006	
505	Louver Stopper	9358555002	9358555002	9358555002	9358555002	9358555002	9358555002	
506	Louver Rod	9358559000	9358559000	9358559000	9358559000	9358559000	9358559000	
508	Cosmetic Panel-R	9358535011	9358535011	9358535011	9358535011	9358535011	9358535011	
509	Cosmetic Panel-L	9358536018	9358536018	9358536018	9358536018	9358536018	9358536018	
514	Control Box Cover	9359097006	9359097006	9359097006	9359097006	9359097006	9359097006	
520	Flap Base	9358537015	9358537015	9358537015	9358537015	9358537015	9358537015	
521	Louver Link Cover	9358558003	9358558003	9358558003	9358558003	9358558003	9358558003	
552	Insulation (Eva.)-R	9358575000	9358575000	9358575000	9358575000	9358575000	9358575000	
553	Insulation (Eva.)-L	9358857007	9358857007	9358857007	9358857007	9358857007	9358857007	
554	Flap Link-Upper (Step Motor-V)	9358551004	9358551004	9358551004	9358551004	9358551004	9358551004	
555	Flap Link-Lower (Step Motor-V)	9358552001	9358552001	9358552001	9358552001	9358552001	9358552001	
558	Motor Rod-A (Step Motor-V)	9358550007	9358550007	9358550007	9358550007	9358550007	9358550007	
574-1	Evaporator Fixture-R (Bracket)	9358589007	9358589007	9358589007	9358589007	9358589007	9358589007	
574-2	Evaporator Fixture-L (Bracket)	9358590003	9358590003	9358590003	9358590003	9358590003	9358590003	
577	Catch TL-119	9359096009	9359096009	9359096009	9359096009	9359096009	9359096009	
578	Base Bracket (Reinforcement Metal)	9358586006	9358586006	9358586006	9358586006	9358586006	9358586006	
580	Top Cover	9358534014	9358534014	9358534014	9358534014	9358534014	9358534014	
581	Protector, Metal (Fan Motor)	9359282006	9359282006	9359282006	9359282006	9359282006	9359282006	
588-1	Evaporator Bracket-R	9358587003	9358587003	9358587003	9358587003	9358587003	9358587003	
588-2	Evaporator Bracket-L	9358588000	9358588000	9358588000	9358588000	9358588000	9358588000	
625	Cord Bushing KR-51	9359240006	9359240006	9359240006	9359240006	9359240006	9359240006	
628	Locking Spacer-B	313005446558	313005446558	313005446558	313005446558	313005446558	313005446558	
629-1	EMI Filter	0400197119	0400197119	0400197119	0400197119	0400197119	0400197119	
652-1	Thermistor Holder Pipe	313806262805	313806262805	313806262805	313806262805	313806262805	313806262805	
653-1	Bolt (Fan Motor Fixing)	0700156014	0700156014	0700156014	0700156014	0700156014	0700156014	
653-2	Bolt	0700190018	0700190018	0700190018	0700190018	0700190018	0700190018	
684	Motor Base	9358562000	9358562000	9358562000	9358562000	9358562000	9358562000	
689	Screw, Grip Tapping SN+4016 ZNY w/Grip	9357837000	9357837000	9357837000	9357837000	9357837000	9357837000	
731-2	Holder (Guide Rail)	0600241018	0600241018	0600241018	0600241018	0600241018	0600241018	
735	Distributor Assy	9358814000	9358814000	9358814000	9358814000	9358814000	9358814000	
743	Remote Control Unit Holder	9359955016	9359955016	9359955016	9359955016	9359955016	9359955016	
755	Casing Cover	9358544006	9358544006	9358544006	9358544006	9358544006	9358544006	
764	Drain Cap	9358746004	9358746004	9358746004	9358746004	9358746004	9358746004	
771	Panel Assy "FUJI ELECTRIC"	9359076032	9359076032	9359076032	9359076032	9359076032	9359076032	
815-1	Terminal 3P	9356488005	9356488005	9356488005	9356488005	9356488005	9356488005	
815	Terminal 4P	9358660012	9358660012	9358660012	9358660012	9358660012	9358660012	
815	Terminal 7P	9358660102	9358660102	9358660102	9358660102	9358660102	9358660102	
824-3	Fuse BET3.15A-250V	0600222512	0600222512	0600222512	0600222512	0600222512	0600222512	
868	PCB Holder	9358547007	9358547007	9358547007	9358547007	9358547007	9358547007	
870-1	Arm	9358565001	9358565001	9358565001	9358565001	9358565001	9358565001	
870-2	Center Arm	9359280002	9359280002	9359280002	9359280002	9359280002	9359280002	
875	Filter PCB Assy EZ-0964HSE-P	9702081010	9702081010	9702081010	9702081010	9702081010	9702081010	
876-1	Step Motor-H	9359106012	9359106012	9359106012	9359106012	9359106012	9359106012	
876-2	Step Motor-V	9359105015	9359105015	9359105015	9359105015	9359105015	9359105015	
923	Control Box Bracket	9358717004	9358717004	9358717004	9358717004	9358717004	9358717004	
982	Cord Clamp	9357864006	9357864006	9357864006	9357864006	9357864006	9357864006	

OPTIONAL PARTS FOR INDOOR UNIT

Ref. No.	Description	Part No.	Q'ty
772	Joint Pipe-A	9302812021	

When you order parts, please make a photocopy of this page and fill the number of the parts in the "Order" column.

OUTDOOR UNIT

Ref. No.	Description	Part No.						Ord.
		ROY-14AA	ROY-14RA	RO-18AC	ROW-18RB	ROW-24CA	ROW-24RE	Q'ty
2	Fan Cover	9304109006	9304109006	9350214020	9350214020	9350214020	9350214020	
4	Emblem-Rear "FUJI ELECTRIC"	9301702019	9301702019	9301702019	9301702019	9301702019	9301702019	
5	Cabinet, Painted	9302936017	9302936017	—	—	—	—	
5	Cabinet-A, Painted	—	—	9303876015	9303876015	9303876015	9303876015	
6	Cabinet-C, Painted	—	—	9353549013	9353549013	9353549013	9353549013	
7	Connector Cover (Cabinet)	9357970004	9357970004	—	—	—	—	
7	Connector Cover	—	—	9358011010	9358011010	9358011010	9358011010	
8	Wire Assy (Shield)-D	—	—	9359904076	—	9359904052	—	
8	Shield Tube Assy-D	—	—	—	9359904052	—	9359904052	
9	Cabinet Rear Panel	9303744017	9303744017	—	—	—	—	
9	Cabinet-B, Painted	—	—	9303874011	9303874011	9303874011	9303874011	
10	Noise Insulation-E	—	—	313791106305	313791106305	313791106305	313791106305	
11	Noise Insulation-B	—	—	—	—	—	313791106100	
12	Base Assy, Painted	9354493070	9354493070	9353452054	9353452054	9353452061	9353452061	
13	3-Way Valve	9364616001	9364616001	—	—	—	—	
13	3-Way Valve Assy	—	—	9364523002	9364523002	9364523002	9364523002	
14	2-Way Valve	9364615004	9364615004	—	—	—	—	
14	2-Way Valve Assy	—	—	9365021002	9365021002	9365021002	9365021002	
15	Dryer	—	313523082505	9353789006	9353789006	9368111014	9365109014	
16	Condenser Assy	9365671009	9365670002	9353455055	9353455048	9356015010	9363794014	
17	"U" Pipe-Y	—	—	—	313728127102	—	9305523009	
18	Suction Pipe	9364832005	9364827001	—	—	—	—	
18	Suction Pipe Assy	—	—	9364274003	—	—	—	
19	Capillary Tube	9364835006	—	9364270005	—	—	—	
19-3	Capillary Tube (Cool)	—	—	—	—	9364327006	—	
20	Discharge Pipe Assy	9364830001	9364826004	—	—	—	—	
20	Discharge Pipe	—	—	9364271002	9367136001	9368491000	—	
26	Compressor Cover-A	—	—	9363020007	—	9368504007	—	
26	Compressor Cover	—	—	—	9367296002	—	9367134007	
26-1	Compressor Cover-B	—	—	—	—	9368505004	—	
29	Separate Wall	—	—	313986033213	313986033213	313986033213	313986033213	
32-1	Control Box Metal-A	—	—	9365672013	9353595003	9365672013	9353595003	
32-2	Control Box Metal-A	9355843003	9355843003	—	—	—	—	
34	Capacitor (Fan Motor)	9700468080	9700468080	9357965017	9357965024	9357965017	9357965024	
36	Cord Holder Metal	—	—	9356934007	—	9356934007	—	
36-2	Cord Holder Metal	—	—	—	9356362008	—	9356362008	
37	Running Capacitor	9356386066	9356386066	9703107016	9703107153	9703107016	9703107122	
38	Capacitor Clamp Metal	313468061808	313468061808	9351770013	9351770013	9351770013	9351770013	
39	Propeller Fan Assy	9351589011	9351589011	9300855013	—	9300855013	—	
39	Propeller Fan	—	—	—	9300855013	—	9300855013	
41	Fan Motor Assy-Out	—	—	9600738023	9600738047	9600738023	9600738047	
42	Bracket (Motor)	313166243804	313166243804	—	—	—	—	
45	Motor Fixing Table Assy	—	—	313029311100	313029311100	313029311100	313029311100	
46	Compressor Assy	—	—	9367240005	9361733000	9367112005	9367112005	
51	Special Nut M5 (For Comp.)	9359430018	9359430018	9300301015	—	—	—	
54-1	Outlet Pipe-A	—	—	—	—	—	9365391014	
54-2	Outlet Pipe (Cond.)-B	—	—	—	—	—	9365391068	
55	Special Nut M8 (For Comp.)	9355091008	9355091008	313252257701	9355091008	9355091008	9355091008	
58	Suction Pipe Assy	—	—	—	—	9368492007	—	
67	Rubber (Vibration-proof)	—	—	313659068604	313659068604	313659068604	313659068604	
81	Strap	—	—	—	9362371001	9362371001	9362371001	
98	Fan Ring	313166296109	313166296109	—	—	—	—	
105	Compressor Assy	9364723006	9364723006	—	—	—	—	
107	Rubber Seat-A (For Comp.)	9359425014	9359425014	9351049010	9362368001	9362368001	9362368001	
109	Terminal Cover (For Comp.)	9364724003	9364724003	9351048013	9362369008	9362369008	9362369008	
117-3	Hex. Nut w/Spring Washer	—	—	301721180114	301721180114	301721180114	301721180114	
138	Separate Wall Assy	9303729014	9303729014	—	—	—	—	
164	Fan Motor Assy-Out	9601113010	9601113010	—	—	—	—	
178-1	Capillary Holder Rubber	—	—	313414274807	—	—	—	
187	Clamp No. 1219	—	—	313361271706	313361271706	313361271706	313361271706	

OUTDOOR UNIT (Continued)

When you order parts, please make a photocopy of this page and fill the number of the parts in the "Order" column.

Ref. No.	Description	Part No.						Ord.
		ROY-14AA	ROY-14RA	RO-18AC	ROW-18RB	ROW-24CA	ROW-24RE	Q'ty
196-1	Clamp SKB-3M	—	—	—	312300787605	312300787605	—	
218-3	Power Relay	—	—	9704171016	—	9704171016	—	
232	Joint Pipe	—	—	—	9365312032	—	9365312032	
259	Muffler	—	313505083900	—	—	—	—	
271	Rubber (4-Way Valve)	—	—	—	313728251908	—	313728251908	
272	Strainer	9357309002	9301340006	—	—	—	—	
300	Suction Pipe-C	—	—	—	9367138005	—	9367125005	
328	Compressor Plate-B	—	—	9363049015	—	9367128037	—	
328	Compressor Pipe Assy	—	—	—	9367128020	—	9367128013	
329	Coupling Pipe Assy	—	9352375002	—	—	—	—	
330	Inlet Pipe-A Assy	—	—	—	9366859017	—	—	
332-1	Suction Pipe-D	—	—	—	9367135004	—	9367126002	
332-2	Suction Pipe-E	—	—	—	9350600007	—	9350600007	
333	Accumulator	—	—	—	9350363018	—	313986117201	
334	Suction Pipe-B	—	—	—	9367137008	—	9367124008	
335	Insulation (Accumulator)	—	—	—	313681188608	—	313681188608	
338	Motor Fixture Metal	—	—	313029297108	313029297108	313029297108	313029297108	
343	Solenoid Coil	—	9704061034	—	9359616092	—	9359616092	
344	4-Way Valve	—	9307556012	—	313943302804	—	9300604017	
348	Outlet Pipe (Cond.)	—	—	—	—	9363041019	—	
348-1	Outlet Pipe-B	—	—	—	9365391020	—	—	
348-2	Outlet Pipe-A	—	—	—	9365391075	—	—	
353	Valve-A Assy	—	—	9364268002	—	9364325002	—	
360	4-Way Valve Band	—	—	—	313986251802	—	313986251802	
373	Grip	313166178700	313166178700	—	—	—	—	
412	Terminal Gasket (For Comp.)	9364725000	9364725000	—	9362370004	—	9362370004	
412	Terminal Gasket	—	—	9351051013	—	9362370004	—	
420	Capillary Assy	—	9364828008	—	—	—	9367121007	
423	Noise Insulation-F	9350944019	9350944019	—	—	—	—	
456	Pipe-A	9352267017	—	—	—	—	—	
519	Restrictor Valve Assy	—	—	—	9365392058	—	—	
527	Protection Net	9355444002	9355444002	—	—	—	—	
582	Discharge Pipe-F	9301425017	—	—	—	—	—	
646	Compressor Cover-B	—	—	9363021004	9367297009	—	—	
717	Center Plate	—	—	9350216017	9350216017	9350216017	9350216017	
718	Discharge Pipe-C	—	—	—	—	—	9367123001	
734	Cabinet Top Plate	9302937014	9302937014	—	9352161018	—	9352161018	
744	Clamp (Condenser)	313166374106	313166374106	—	—	—	—	
745	Motor Support	313166036308	313166036308	—	—	—	—	
754	Terminal Gasket Washer	—	—	9351053017	—	—	—	
815	Terminal 3P	9355901424	—	—	—	—	—	
815	Terminal 4P	—	9358660041	—	—	—	—	
815	Terminal 5P	—	—	9356497021	9356497021	9356497021	9356497021	
823-2	Fuse Holder	—	—	0500063024	—	0500063024	—	
824-4	Fuse	—	—	0600222529	—	0600222529	—	
826	Condensing Pipe-B Assy	—	9353015006	—	—	—	—	
867	Accumulator Holder Rubber	—	—	—	9354022027	—	9354022010	
909	Strainer-A	—	—	—	—	—	9365112014	
910	Strainer-B	—	—	—	9365099018	—	—	
982-1	Cord Clamp	9356857009	9356857009	—	—	—	—	
982-2	Cord Clamp-B	9356858006	9356858006	—	—	—	—	
987	Insulation Sheet	9358372005	9358372005	—	—	—	—	

RYT-14 / ROY-14AA
 RYT-14R / ROY-14RA
 RYT-18AC / RO-18AC
 RYT-18RB / ROW-18RB
 RYT-24CA / ROW-24CA
 RYT-24RE / ROW-24RE

When you order parts, please make a photocopy of this page and fill the number of the parts in the "Order" column.

CONTROLLER PCB ASSEMBLY (Ref. No. 236)

() : Reverse cycle model

Ref. No.	Description	Part No.	Ord. Q'ty	Ref. No.	Description	Part No.	Ord. Q'ty
IC1	IC μ PD78014HCW-013	9702426026		R54	Res. 1/10W 47 Ω \pm 5%	0200212425	
IC2	IC NJM7812FA	0100462104		CJ1,2	Res. 0 Ω	0200212012	
IC3	IC NJM7805FA	0100462081		C5	Cap. Elec. 450V 100 μ F	0300256060	
IC4~6	Xstr μ PA2003GR	0100028041		C6	Cap. Plastic 4700pF	0300269091	
IC7	IC NM82C46M8-X	0101622026		C7	Cap. Plastic 50V 0.047 μ F	0300169339	
IC8	IC PST600CMTR	0101461120		C8	Cap. Elec. 25V 100 μ F	0301197560	
IC9	Photocoupler TLP621(D4)-GB	0000117074		C9	Cap. Elec. 25V 1000 μ F	0301196495	
Q1	Xstr 2SC4236	0000164047		C10,11,33,	Cap. Elec. 25V 10 μ F	0301192312	
Q2	Xstr 2SC1740S	0000699235		36,41			
Q3,4	Xstr DTC124EK	0000936033		C12	Cap. Elec. 25V 1000 μ F	0301158264	
D1	Diode D3SB60	0000689045		C13,15,34,	Cap. Ceramic 50V 0.1 μ F	0300311752	
D2,4,7	Diode D1FL20U	0000746519		37,39,44,45			
D3	Diode MTZJ5.1B	0000852166		C14	Cap. Elec. 25V 100 μ F	0301192350	
D5	Diode 1SR139-600	0000353120		C16-31,38,	Cap. Ceramic 50V 0.01 μ F	0300311738	
D6	Diode D2FL20U	0000906500		40,42,46,49			
D8	Diode D1F60	0000208024		C32,35,43,	Cap. Ceramic 50V 1000pF	0300308509	
D9	Diode DA226U	0000625036		50~53			
D12	Diode DAN202K	0000684019		C54	Cap. Ceramic 0.01 μ F	0300209158	
R1	Res. Wire Wound 5W 3.3 Ω \pm 5%	0200244372		K1,3, 4, (6, 7)	Relay JQ1-12V	9701316014	
R2	Res. Metal Oxide 2W 1.5 Ω \pm 5%	0201107119		(K5)	Relay JQ1P-12V	9701794010	
R3	Res. 1/10W 100 Ω \pm 5%	0200212500		SSR1	Relay G3M-202P-UTU	9701829019	
R4	Res. Carbon 1W 220k Ω \pm 5%	0200111353		(SW1)	Switch Slide DSS803	9701392018	
R5	Res. Metal Oxide 2W 47k Ω \pm 5%	0201107652		T1	Switching Transformer ETS28AS118AH	9702727017	
R6	Res. 1/2W 100 Ω \pm 5%	0200731506		(T1)	Switching Transformer MPR-1	9701976010	
R7	Res. 1/4W 330 Ω \pm 5%	0200708621		X1	Ceramic Resonator EFOEC8384T4	9701261017	
R8,10,13, 15~17,21~24, 29~32,37, 39,48,50, 52,53,55, 59,68	Res. 1/10W 390 Ω \pm 5%	0200212647		BZ1	Buzzer PKM13EPY-4000-TF01	9701298013	
R9,47	Res. Metal Oxide 1W 56k Ω \pm 5%	0201106662		CR1, (2, 3)	Network RPEL-121204	9701125012	
R11	Res. 1/10W 1k Ω \pm 5%	0200212746		CN1	Plug, PCB B2P3-VH-B-C	0500011773	
R12,18~20, 25~28, 33~36, 38,42,44, 46,49,51, 56~58,67	Res. 1/10W 4.7k Ω \pm 5%	0200212906		(CN2)	Plug, PCB B3P5-VH-B-R	0500011803	
R40,41	Res. 1/10W 10k Ω \pm 5%	0200279497		CN4	Plug, PCB B2P3-VH-B-Y	0500011827	
R43	Res. 1/10W 49.9k Ω \pm 5%	0200279824		CN5	Plug, PCB 5430C063	0500957026	
R45				CN6	Plug, PCB B2P3-VH-B-E	0500011759	
				CN7	Plug, PCB B2B-XAKK-1-A	0501045227	
				CN8	Plug, PCB B2B-XASK-1-A	0501045012	
				CN9	Plug, PCB B2P-SHF-1AA	0500006069	
				CN10	Plug, PCB B5B-XASK-1-A	0501045043	
				CN11	Plug, PCB B5B-XARK-1-A	0501045517	
				CN12	Plug, PCB B3B-XASK-1-A	0501045029	
				CN13	Plug, PCB B8B-XASK-1-A	0501045074	
				CN14	Plug, PCB B4B-XH-AM	0500005314	
				CN15	Plug, PCB B3B-XARK-1-A	0501045319	











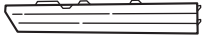

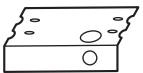

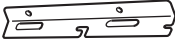
INDICATOR PCB ASSEMBLY (Ref. No. 385)

Ref. No.	Description	Part No.	Ord. Q'ty	Ref. No.	Description	Part No.	Ord. Q'ty
D201	Diode SLR-325VC RED	0000813259		PHA201	Remote Control Amplifier SBX1810-22	0101525129	
D202	Diode SLR-325MC GRN	0000813242		SW201	Switch, EVQ-PAG-04K	9700450016	
D203, 204	Diode SLR-325DC ORG	0000813235		CN201	Wire w/Connector JC25/XMR	9701875016	
C201	Cap. Ceramic 0.1 μ F	0300988251			Lamp Holder 94N40	9358548004	
C202	Cap. Elec. 25V 10 μ F	0300004258		JM201	Wire 0.6dia. L=10mm	9700025016	
R201~204	Res. Carbon 1/4W 330 Ω \pm 5%	0201038659					

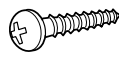

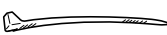

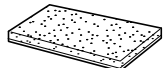
FILTER PCB ASSEMBLY (Ref. No. 875)

Ref. No.	Description	Part No.	Ord. Q'ty	Ref. No.	Description	Part No.	Ord. Q'ty
C101, 102	Cap. Plastic 0.22 μ F	0300304099		F101	Fuse BET 3.15A-250V	0600222512	
C105, 106	Cap. Plastic 0.022 μ F	0301052098		FH1, 2	Fuse Holder PFC5000-0502	0500158072	
SA101	Arrester DSA-362MA-05	0600168032		E101	Wire w/Terminal L=120mm GRN	9702066062	
VA101, 102	Varistor TNR10V471K	0000361224		W101	Wire w/Terminal L=80mm BLK	9702066017	
TM101, 102	Plug Contact 86028	0500536016		W102	Wire w/Terminal L=100mm WHT	9702066024	
LF101	EMI Filter ELF17N015A	0400197119		W103, 104	Wire #18 2p	9702067014	



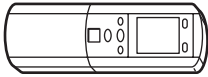

INDOOR UNIT ACCESSORIES

Name and Shape	Application	Part No.		
		RYT-14 RYT-14R	RYT-18AC RYT-18RB RYT-24CA RYT-24RE	
Cosmetic Panel-L 		9358536018	9358536018	
Cosmetic Panel-R 		9358535011	9358535011	
Tapping screw (ø4 x 10) 		301171164104	301171164104	
Installation template 	For positioning the indoor unit. For under ceiling type.	9359107002	9359107002	
Hanger bracket-L 	For suspending the indoor unit from ceiling.	9358596005	9358596005	
Hanger bracket-R 		9358595008	9358595008	
Anchor bolt (M12) 		} 313806339400	} 313806339400	
Special nut 				
Spring washer 		301821112213	301821112213	
Wall bracket 		For suspending the indoor unit on the wall.	9358597002	9358597002
Tapping screw (ø4 x 20) 		For fixing the wall bracket.	301141164200	301141164200
Coupler heat insulator (large) 	For indoor side pipe joint. (Large pipe)	9350716012	9350716012	
Coupler heat insulator (small) 	For indoor side pipe joint. (Small pipe)	—	313209328104	
Nylon fastener (large) 	For fixing the coupler heat insulator.	313152375801	—	
Nylon fastener (small) 	For fixing the drain hose.	312300787605	312300787605	
Drain hose 		9359242000	9359242000	
Insulation (drain hose) 	Adhesive type 70 x 230	9359225003	9359225003	
VT wire 	For fixing the drain hose L 280 mm	313806350303	313806350303	

REMOTE CONTROL UNIT

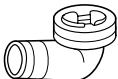
Name and Shape	Application	Part No.	
		RYT-14 RYT-18AC RYT-24CA	RYT-14R RYT-18RB RYT-24RE
Remote control unit 	Use for air conditioner operation	9359913061 (AR-DL6)	9359913054 (AR-DL5)
Battery (penlight) 	For remote control unit	313187358304	313187358304
Remote control unit holder 	For mounting the remote control unit	9359955016	9359955016
Tapping screw (ø3 x 12) 	For remote control unit holder installation	301141533125	301141533125

OUTDOOR UNIT ACCESSORIES

Name and Shape	Application	Part No.			
		ROY-14AA	ROY-14RA	RO-18AC ROW-24CA	ROW-18RB ROW-24RE
Hexagon wrench 	For air purge	9351228019	9351228019	9351228019	9351228019
Drain pipe 	For outdoor unit drain piping work (May not be supplied, depending on the model)	—	9303029015	—	—
Drain pipe 		—	—	—	313728031005
Flexible tube 		—	—	—	313013042915
Drain cap 		—	313166024302	—	313166024302



MANUFACTURER :

Fuji Denki Sosetsu Co., Ltd.

Tokyo, Japan



Большая библиотека технической документации

<https://splitsystema48.ru/instrukcii-po-ekspluatácii-kondicionerov.html>

каталоги, инструкции, сервисные мануалы, схемы.